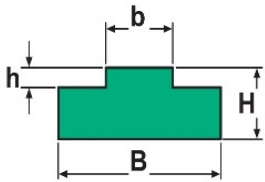
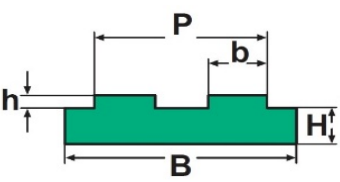
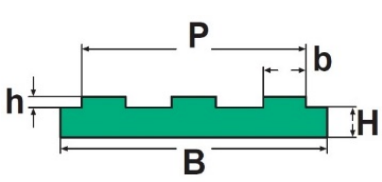
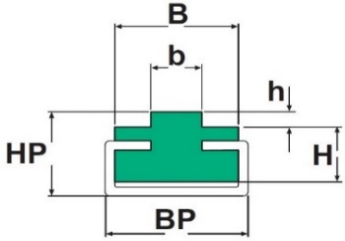
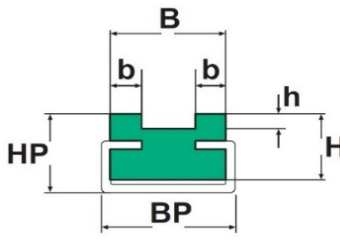
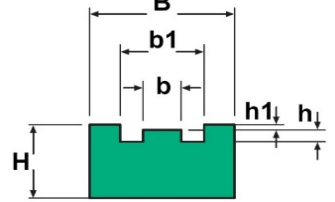
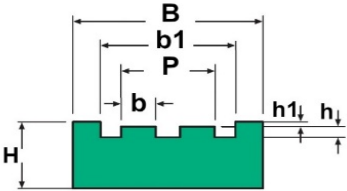
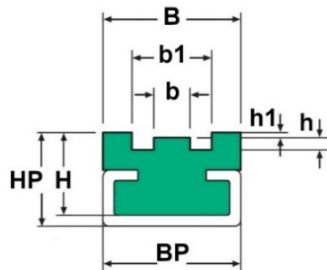
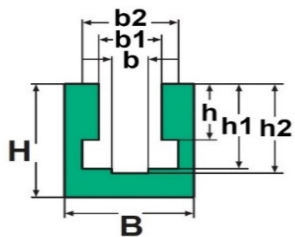
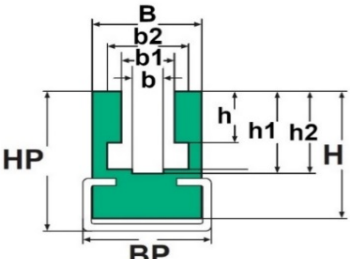
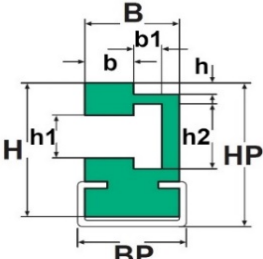
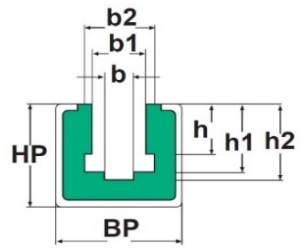
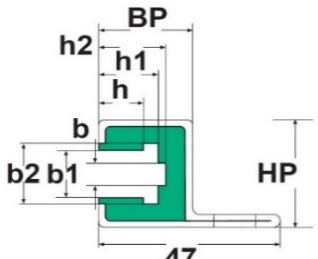
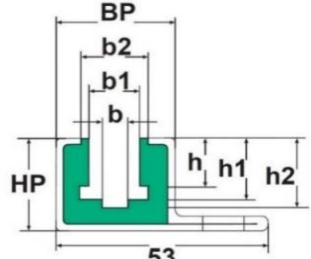
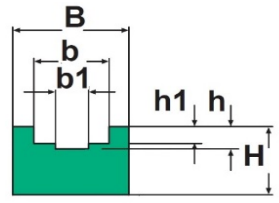
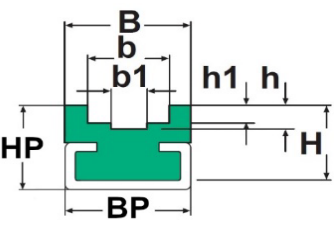

|  |  |   |
|--|--|---|
| <p>1T - pro řetězy / for chains 06B-1 až 32B-1</p>      | <p>2T - pro řetězy / for chains 06B-2 až 32B-2</p>    | <p>3T - pro řetězy / for chains 06B-3 až 16B-3</p>   |
| <p>1TC - pro řetězy / for chains 06B-1 až 20B-1</p>     | <p>2TC - pro řetězy / for chains 06B-2 až 16B-2</p>   | <p>1E - pro řetězy / for chains 06B-1 až 16B-1</p>   |
| <p>2E - pro řetězy / for chains 06B-2 až 16B-2</p>     | <p>2EC - pro řetězy / for chains 06B-2 až 16B-2</p>    | <p>1BL - pro řetězy / for chains 06B-1 až 16B-1</p>   |
| <p>1BLC - pro řetězy / for chains 06B-1 až 16B-1</p>  | <p>1CB - pro řetězy / for chains 06B-1 až 16B-1</p>   | <p>1CP - pro řetězy / for chains 06B-1 až 16B-1</p>    |
| <p>1BKC14 - řetězy / chains 06B-1 až 12B-1</p>        | <p>1BKC15 - řetězy / chains 06B-1 až 12B-1</p>    | <p>1U - pro řetězy / for chains 06B-1 až 16B-1</p>   |
| <p>1UC - pro řetězy / for chains 06B-1 až 16B-1</p>   | <p>Standardní délka 2 METRY<br/>(jiné délky na vyžádání)<br/>Materiál: PE-UHMW (PE-1000)<br/>Barva: zelená<br/>Specifická hmotnost: 0,945 g/cm3<br/>Dynamic friction coefficient: 0,2<br/>Operating temperature: -70°C +65°C</p> | <p>Standard Length 2 METRES<br/>(Other lengths on request)<br/>Material: PE-UHMW (PE-1000)<br/>Color: green<br/>Specific weight: 0.945 g/cm3<br/>Dynamic friction coefficient: 0.2<br/>Operating temperature: -70°C +65°C</p> |

**Upozornění: U vedení pro C - profily nejsou C - profily součástí dodávky. C - profily je nutno objednávat jako samostatnou položku. /**

Note: C - profiles are not included. The C-profile of the appropriate size must be ordered as a separate item.

## Vedení pro klínové, ploché, ozubené a kruhové řemeny - přehled typů

Guide for V-Belts, Flat, Timing and Round Belts - Product Range

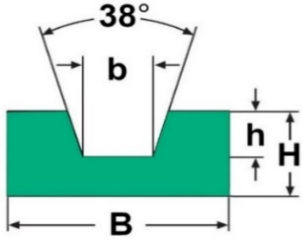
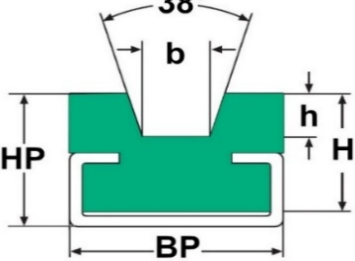
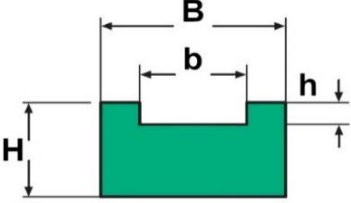
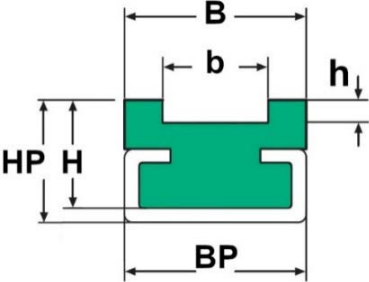
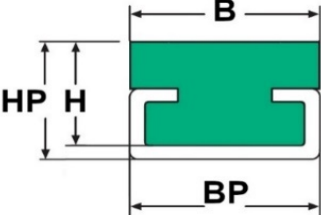
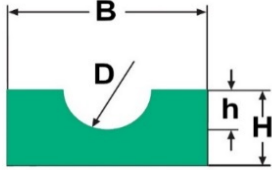
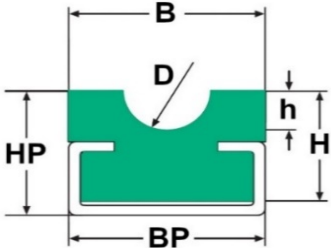
|  |   |  |
|--|---|--|
| <p>V - pro klínové řemeny / for V-belts</p>         | <p>VC - pro klínové řemeny / for V-belts</p>   | <p>F - pro ozubené řemeny / for timing belts</p>    |
| <p>FC - pro ozubené řemeny / for timing belts</p>    | <p>PC - pro ploché řemeny / for flat belts</p>   | <p>R - pro kruhové řemeny / for round belts</p>   |
| <p>RC - pro kruhové řemeny / for round belts</p>  | <p>Standardní délka 2 METRY<br/>(jiné délky na vyžádání)<br/>Materiál: PE-UHMW (PE-1000)<br/>Barva: zelená<br/>Specifická hmotnost: 0,945 g/cm<sup>3</sup><br/>Dynamic friction coefficient: 0.2<br/>Operating temperature: -70°C +65°C</p> | <p>Standard Length 2 METRES<br/>(Other lengths on request)<br/>Material: PE-UHMW (PE-1000)<br/>Color: green<br/>Specific weight: 0.945 g/cm<sup>3</sup><br/>Dynamic friction coefficient: 0.2<br/>Operating temperature: -70°C +65°C</p> |

**Upozornění: U vedení pro C - profily nejsou C - profily součástí dodávky. C - profily je nutno objednávat jako samostatnou položku. /**  
Note: C - profiles are not included. The C-profile of the appropriate size must be ordered as a separate item.

## Kovové C-profilý k plastovým vedením řetězů a řemenů

Metal C-Profiles for Chain and Belt Guides

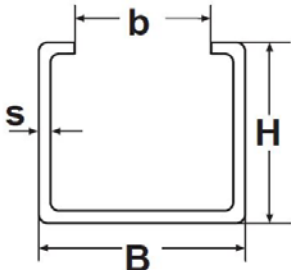
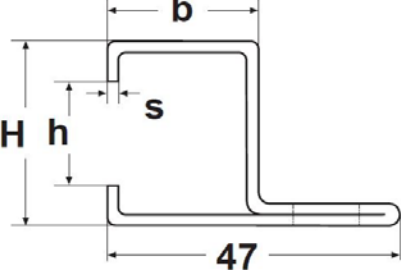
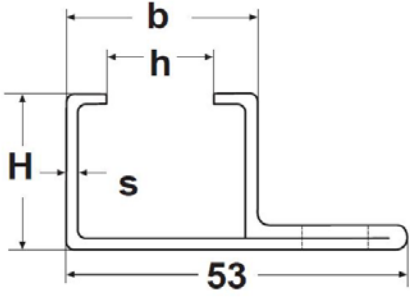
|   |  |   |
|---|--|---|
| <p>C3 - C5 - C9 - C10 - C11</p>                  | <p>C-14</p>   | <p>C-15</p>  |
| <p>Standardní délka 2 METRY<br/>(jiné délky na vyžádání)<br/>Materiál: ST - ocel galvanicky pozinkovaná, SS - nerezavějící ocel</p> | <p>Standard Length 2 METRES<br/>(Other lengths on request)<br/>Material: ST - galvanized steel, SS - stainless steel INOX AISI 304</p> |   |

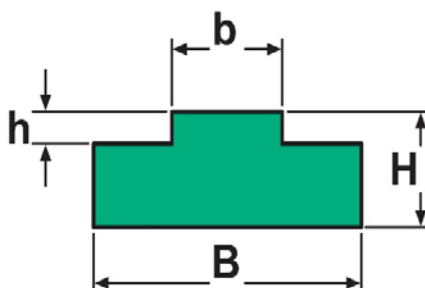

**Standardní délka 2 METRY**

(jiné délky na vyžádání)

Materiál: PE-UHMW vysokomolekulární polyetylen (PE-1000)

Barva: zelená

Specifická hmotnost: 0,945 g/cm<sup>3</sup>

Koeficient tření: 0,2 (P = 0,05 N/mm<sup>2</sup> – v = 0,6 m/s – t = 40°C)

Provozní teplota: -70°C +65°C

Lineární tepelná roztažnost: 2 mm každých 10°C, počínaje t = 20°C

**Standard Length 2 METRES**

(Other lengths on request)

Material: PE-UHMW High Molecular Weight Polyethylene (PE-1000)

Color: green

Specific weight: 0.945 g/cm<sup>3</sup>

Dynamic friction coefficient: 0.2 (P = 0.05N/mm<sup>2</sup> – v = 0.6 m/s – t = 40°C)

Operating temperature: -70°C +65°C

Linear thermal expansion: 2 mm every 10°C, starting from a temp. of 20°C

### Typ 1T - pro jednořadé válečkové řetězy dle DIN 8187 / for simple roller chains DIN 8187

| Typ<br>Type    | Výrobní číslo<br>Product No. | Typ řetězu<br>Chain Type | B<br>(mm) | H<br>(mm) | b<br>(mm) | h<br>(mm) |  |  |  |  |  |  | m<br>(kg) |
|----------------|------------------------------|--------------------------|-----------|-----------|-----------|-----------|--|--|--|--|--|--|-----------|
| 1T 06B-1 15x10 | S1T010URG                    | 06B-1                    | 15        | 10        | 5,4       | 1,50      |  |  |  |  |  |  | 0,27      |
| 1T 08B-1 20x10 | S1T110URG                    | 08B-1                    | 20        | 10        | 7,4       | 2,20      |  |  |  |  |  |  | 0,32      |
| 1T 08B-1 20x15 | S1T115URG                    | 08B-1                    | 20        | 15        | 7,4       | 2,20      |  |  |  |  |  |  | 0,53      |
| 1T 08B-1 20x20 | S1T120URG                    | 08B-1                    | 20        | 20        | 7,4       | 2,2       |  |  |  |  |  |  | 0,71      |
| 1T 10B-1 20x10 | S1T210URG                    | 10B-1                    | 20        | 10        | 9,2       | 2,60      |  |  |  |  |  |  | 0,31      |
| 1T 10B-1 20x15 | S1T215URG                    | 10B-1                    | 20        | 15        | 9,2       | 2,6       |  |  |  |  |  |  | 0,54      |
| 1T 10B-1 20x20 | S1T220URG                    | 10B-1                    | 20        | 20        | 9,2       | 2,60      |  |  |  |  |  |  | 0,73      |
| 1T 12B-1 25x10 | S1T310URG                    | 12B-1                    | 25        | 10        | 11,3      | 2,40      |  |  |  |  |  |  | 0,44      |
| 1T 12B-1 25x15 | S1T315URG                    | 12B-1                    | 25        | 15        | 11,3      | 2,40      |  |  |  |  |  |  | 0,66      |
| 1T 12B-1 25x20 | S1T320URG                    | 12B-1                    | 25        | 20        | 11,3      | 2,4       |  |  |  |  |  |  | 0,87      |
| 1T 16B-1 40x15 | S1T415URG                    | 16B-1                    | 40        | 15        | 16,5      | 3,50      |  |  |  |  |  |  | 0,93      |
| 1T 16B-1 40x20 | S1T420URG                    | 16B-1                    | 40        | 20        | 16,5      | 3,50      |  |  |  |  |  |  | 1,30      |
| 1T 20B-1 45x15 | S1T515URG                    | 20B-1                    | 45        | 15        | 19        | 4,3       |  |  |  |  |  |  | 1,04      |
| 1T 20B-1 45x20 | S1T520URG                    | 20B-1                    | 45        | 20        | 19        | 4,3       |  |  |  |  |  |  | 1,48      |
| 1T 24B-1 60x15 | S1T615URG                    | 24B-1                    | 60        | 15        | 24,6      | 5,6       |  |  |  |  |  |  | 1,32      |
| 1T 24B-1 60x20 | S1T620URG                    | 24B-1                    | 60        | 20        | 24,6      | 5,6       |  |  |  |  |  |  | 1,91      |
| 1T 28B-1 75x20 | S1T720URG                    | 28B-1                    | 75        | 20        | 30        | 6,9       |  |  |  |  |  |  | 2,25      |
| 1T 32B-1 80x20 | S1T820URG                    | 32B-1                    | 80        | 20        | 30        | 7,8       |  |  |  |  |  |  | 2,28      |

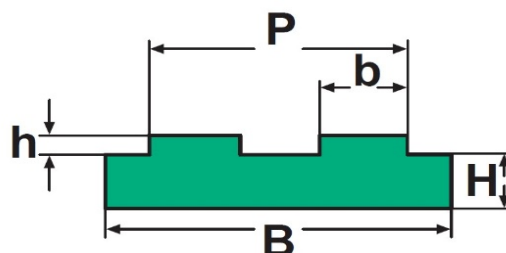

Standardní délka 2 METRY

(jiné délky na vyžádání)

Materiál: PE-UHMW vysokomolekulární polyetylen (PE-1000)

Barva: zelená

Specifická hmotnost: 0,945 g/cm<sup>3</sup>

Koeficient tření: 0,2 (P = 0,05 N/mm<sup>2</sup> – v = 0,6 m/s – t = 40°C)

Provozní teplota: -70°C +65°C

Lineární tepelná roztažnost: 2 mm každých 10°C, počínaje t = 20°C

Standard Length 2 METRES

(Other lengths on request)

Material: PE-UHMW High Molecular Weight Polyethylene (PE-1000)

Color: green

Specific weight: 0.945 g/cm<sup>3</sup>

Dynamic friction coefficient: 0.2 (P = 0.05N/mm<sup>2</sup> – v = 0.6 m/s – t = 40°C)

Operating temperature: -70°C +65°C

Linear thermal expansion: 2 mm every 10°C, starting from a temp. of 20°C

**Typ 2T - pro dvouřadé válečkové řetězy dle DIN 8187 / for double roller chains DIN 8187**

| Typ<br>Type     | Výrobní číslo<br>Product No. | Typ řetězu<br>Chain Type | B<br>(mm) | H<br>(mm) | b<br>(mm) | h<br>(mm) | P<br>(mm) |  |  |  |  |  | m<br>(kg) |
|-----------------|------------------------------|--------------------------|-----------|-----------|-----------|-----------|-----------|--|--|--|--|--|-----------|
| 2T 06B-2 25x10  | S2T010URG                    | 06B-2                    | 25        | 10        | 5,4       | 1,5       | 15,8      |  |  |  |  |  | 0,51      |
| 2T 08B-2 35x10  | S2T110URG                    | 08B-2                    | 35        | 10        | 7,4       | 2,2       | 21,4      |  |  |  |  |  | 0,71      |
| 2T 08B-2 35x15  | S2T115URG                    | 08B-2                    | 35        | 15        | 7,4       | 2,2       | 21,4      |  |  |  |  |  | 1,05      |
| 2T 08B-2 35x20  | S2T120URG                    | 08B-2                    | 35        | 20        | 7,4       | 2,2       | 21,4      |  |  |  |  |  | 1,36      |
| 2T 10B-2 40x10  | S2T210URG                    | 10B-2                    | 40        | 10        | 9,2       | 2,6       | 25,8      |  |  |  |  |  | 0,84      |
| 2T 10B-2 40x15  | S2T215URG                    | 10B-2                    | 40        | 15        | 9,2       | 2,6       | 25,8      |  |  |  |  |  | 1,22      |
| 2T 10B-2 40x20  | S2T220URG                    | 10B-2                    | 40        | 20        | 9,2       | 2,6       | 25,8      |  |  |  |  |  | 1,60      |
| 2T 12B-2 45x15  | S2T315URG                    | 12B-2                    | 45        | 15        | 11,3      | 2,4       | 30,8      |  |  |  |  |  | 1,18      |
| 2T 12B-2 45x20  | S2T320URG                    | 12B-2                    | 45        | 20        | 11,3      | 2,4       | 30,8      |  |  |  |  |  | 1,61      |
| 2T 16B-2 65x15  | S2T415URG                    | 16B-2                    | 65        | 15        | 16,5      | 3,5       | 48,4      |  |  |  |  |  | 1,87      |
| 2T 16B-2 65x20  | S2T420URG                    | 16B-2                    | 65        | 20        | 16,5      | 3,5       | 48,4      |  |  |  |  |  | 2,32      |
| 2T 20B-2 70x15  | S2T515URG                    | 20B-2                    | 70        | 15        | 19        | 4,3       | 54,5      |  |  |  |  |  | 1,86      |
| 2T 20B-2 70x20  | S2T520URG                    | 20B-2                    | 70        | 20        | 19        | 4,3       | 54,5      |  |  |  |  |  | 2,49      |
| 2T 24B-2 88x15  | S2T615URG                    | 24B-2                    | 88        | 15        | 24,6      | 5,6       | 73        |  |  |  |  |  | 3,15      |
| 2T 24B-2 88x20  | S2T620URG                    | 24B-2                    | 88        | 20        | 24,6      | 5,6       | 73        |  |  |  |  |  | 4,66      |
| 2T 28B-2 105x25 | S2T720URG                    | 28B-2                    | 105       | 25        | 30        | 6,9       | 89,6      |  |  |  |  |  | 5,66      |
| 2T 32B-2 105x30 | S2T820URG                    | 32B-2                    | 105       | 30        | 30        | 7,8       | 88,7      |  |  |  |  |  | 6,20      |

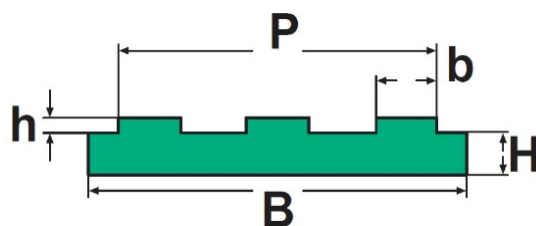

Standardní délka 2 METRY

(jiné délky na vyžádání)

Materiál: PE-UHMW vysokomolekulární polyetylen (PE-1000)

Barva: zelená

Specifická hmotnost: 0,945 g/cm<sup>3</sup>

Koeficient tření: 0,2 (P = 0,05 N/mm<sup>2</sup> – v = 0,6 m/s – t = 40°C)

Provozní teplota: -70°C +65°C

Lineární tepelná roztažnost: 2 mm každých 10°C, počínaje t = 20°C

Standard Length 2 METRES

(Other lengths on request)

Material: PE-UHMW High Molecular Weight Polyethylene (PE-1000)

Color: green

Specific weight: 0.945 g/cm<sup>3</sup>

Dynamic friction coefficient: 0.2 (P = 0.05N/mm<sup>2</sup> – v = 0.6 m/s – t = 40°C)

Operating temperature: -70°C +65°C

Linear thermal expansion: 2 mm every 10°C, starting from a temp. of 20°C

### Typ 3T - pro třířadé válečkové řetězy dle DIN 8187 / for triplex roller chains DIN 8187

| Typ<br>Type    | Výrobní číslo<br>Product No. | Typ řetězu<br>Chain Type | B<br>(mm) | H<br>(mm) | b<br>(mm) | h<br>(mm) | P<br>(mm) |  |  |  |  |  | m<br>(kg) |
|----------------|------------------------------|--------------------------|-----------|-----------|-----------|-----------|-----------|--|--|--|--|--|-----------|
| 3T 06B-3 35x10 | S3T010URG                    | 06B-3                    | 35        | 10        | 5,4       | 1,5       | 25,9      |  |  |  |  |  | 0,62      |
| 3T 08B-3 45x10 | S3T110URG                    | 08B-3                    | 45        | 10        | 7,4       | 2,2       | 35,2      |  |  |  |  |  | 0,78      |
| 3T 08B-3 45x15 | S3T115URG                    | 08B-3                    | 45        | 15        | 7,4       | 2,2       | 35,2      |  |  |  |  |  | 1,20      |
| 3T 08B-3 45x20 | S3T120URG                    | 08B-3                    | 45        | 20        | 7,4       | 2,2       | 35,2      |  |  |  |  |  | 1,63      |
| 3T 10B-3 55x10 | S3T210URG                    | 10B-3                    | 55        | 10        | 9,2       | 2,6       | 42,4      |  |  |  |  |  | 0,92      |
| 3T 10B-3 55x15 | S3T215URG                    | 10B-3                    | 55        | 15        | 9,2       | 2,6       | 42,4      |  |  |  |  |  | 1,58      |
| 3T 10B-3 55x20 | S3T220URG                    | 10B-3                    | 55        | 20        | 9,2       | 2,6       | 42,4      |  |  |  |  |  | 2,16      |
| 3T 12B-3 60x15 | S3T315URG                    | 12B-3                    | 60        | 15        | 11,3      | 2,4       | 50,2      |  |  |  |  |  | 2,36      |
| 3T 12B-3 60x20 | S3T320URG                    | 12B-3                    | 60        | 20        | 11,3      | 2,4       | 50,2      |  |  |  |  |  | 3,50      |
| 3T 16B-3 95x15 | S3T415URG                    | 16B-3                    | 95        | 15        | 16,5      | 3,5       | 80,3      |  |  |  |  |  | 4,20      |
| 3T 16B-3 95x20 | S3T420URG                    | 16B-3                    | 95        | 20        | 16,5      | 3,5       | 80,3      |  |  |  |  |  | 4,60      |

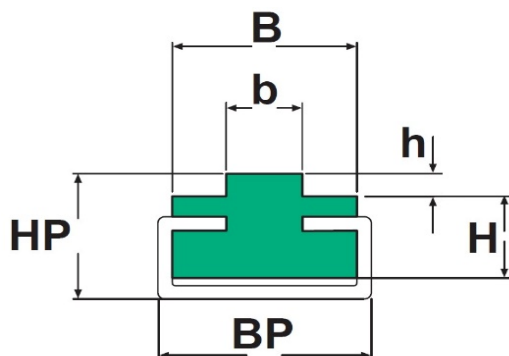

Standardní délka 2 METRY

(jiné délky na vyžádání)

Materiál: PE-UHMW vysokomolekulární polyethylen (PE-1000)

Barva: zelená

Specifická hmotnost: 0,945 g/cm<sup>3</sup>

Koeficient tření: 0,2 (P = 0,05 N/mm<sup>2</sup> – v = 0,6 m/s – t = 40°C)

Provozní teplota: -70°C +65°C

Lineární tepelná roztažnost: 2 mm každých 10°C, počínaje t = 20°C

Standard Length 2 METRES

(Other lengths on request)

Material: PE-UHMW High Molecular Weight Polyethylene (PE-1000)

Color: green

Specific weight: 0.945 g/cm<sup>3</sup>

Dynamic friction coefficient: 0.2 (P = 0.05N/mm<sup>2</sup> – v = 0.6 m/s – t = 40°C)

Operating temperature: -70°C +65°C

Linear thermal expansion: 2 mm every 10°C, starting from a temp. of 20°C

**Typ 1TC - pro jednořadé válečkové řetězy dle DIN 8187 / for simple roller chains DIN 8187**

| Typ<br>Type | Výrobní číslo<br>Product No. | Typ řetězu<br>Chain Type | C-profil *<br>C-Profile * | H<br>(mm) | b<br>(mm) | h<br>(mm) | BP<br>(mm) | HP<br>(mm) |  |  |  | m<br>(kg) |
|-------------|------------------------------|--------------------------|---------------------------|-----------|-----------|-----------|------------|------------|--|--|--|-----------|
| 1TC 06B-1   | S1T0C3URG                    | 06B-1                    | C-3                       | 15        | 5,4       | 1,50      | 20         | 17         |  |  |  | 0,24      |
| 1TC 08B-1   | S1T1C3URG                    | 08B-1                    | C-3                       | 15        | 7,4       | 2,20      | 20         | 17         |  |  |  | 0,27      |
| 1TC 10B-1   | S1T2C3URG                    | 10B-1                    | C-3                       | 15        | 9,2       | 2,60      | 20         | 17         |  |  |  | 0,28      |
| 1TC 12B-1   | S1T3C3URG                    | 12B-1                    | C-3                       | 15        | 11,3      | 2,4       | 20         | 17         |  |  |  | 0,36      |
| 1TC 16B-1   | S1T4C5URG                    | 16B-1                    | C-5                       | 15        | 16,5      | 3,50      | 28         | 18         |  |  |  | 0,58      |
| 1TC 20B-1   | S1T5C9URG                    | 20B-1                    | C-9                       | 20        | 19        | 4,3       | 38         | 27         |  |  |  | 1,28      |

\* Upozornění: C - profily nejsou součástí. C-profil příslušné velikosti je nutno objednávat jako samostatnou položku. /

Note: C - profiles are not included. The C-profile of the appropriate size must be ordered as a separate item.

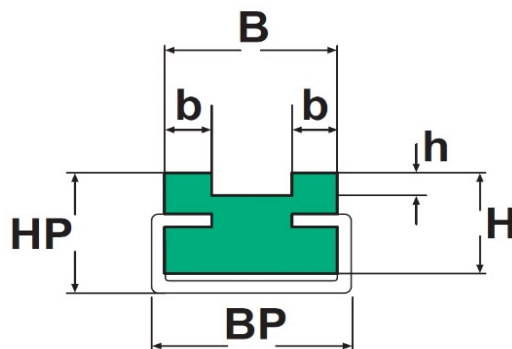

Standardní délka 2 METRY

(jiné délky na vyžádání)

Materiál: PE-UHMW vysokomolekulární polyetylen (PE-1000)

Barva: zelená

Specifická hmotnost: 0,945 g/cm<sup>3</sup>

Koeficient tření: 0,2 (P = 0,05 N/mm<sup>2</sup> – v = 0,6 m/s – t = 40°C)

Provozní teplota: -70°C +65°C

Lineární tepelná roztažnost: 2 mm každých 10°C, počínaje t = 20°C

Standard Length 2 METRES

(Other lengths on request)

Material: PE-UHMW High Molecular Weight Polyethylene (PE-1000)

Color: green

Specific weight: 0.945 g/cm<sup>3</sup>

Dynamic friction coefficient: 0.2 (P = 0.05N/mm<sup>2</sup> – v = 0.6 m/s – t = 40°C)

Operating temperature: -70°C +65°C

Linear thermal expansion: 2 mm every 10°C, starting from a temp. of 20°C

**Typ 2TC - pro dvouřadé válečkové řetězy dle DIN 8187 / for double roller chains DIN 8187**

| Typ<br>Type       | Výrobní číslo<br>Product No. | Typ řetězu<br>Chain Type | C-profil *<br>C-Profile * | B<br>(mm) | H<br>(mm) | b<br>(mm) | h<br>(mm) | BP<br>(mm) | HP<br>(mm) |  |  | m<br>(kg) |
|-------------------|------------------------------|--------------------------|---------------------------|-----------|-----------|-----------|-----------|------------|------------|--|--|-----------|
| 2TC 06B-2 15,7x15 | S2T0C3URG                    | 06B-2                    | C-3                       | 15,7      | 15        | 5,4       | 1,5       | 20         | 17         |  |  | 0,42      |
| 2TC 08B-2 21,4x15 | S2T1C3URG                    | 08B-2                    | C-3                       | 21,4      | 15        | 7,4       | 2,2       | 20         | 17         |  |  | 0,49      |
| 2TC 10B-2 25,9x15 | S2T2C5URG                    | 10B-2                    | C-5                       | 25,9      | 15        | 9,2       | 2,6       | 28         | 19         |  |  | 0,53      |
| 2TC 12B-2 30,7x15 | S2T3C5URG                    | 12B-2                    | C-5                       | 30,7      | 15        | 11,3      | 2,4       | 28         | 19         |  |  | 0,67      |
| 2TC 16B-2 48,3x20 | S2T4C9URG                    | 16B-2                    | C-9                       | 48,3      | 20        | 16,5      | 3,5       | 38         | 27         |  |  | 1,32      |

\* Upozornění: C - profily nejsou součástí. C-profil příslušné velikosti je nutno objednávat jako samostatnou položku. /

Note: C - profiles are not included. The C-profile of the appropriate size must be ordered as a separate item.

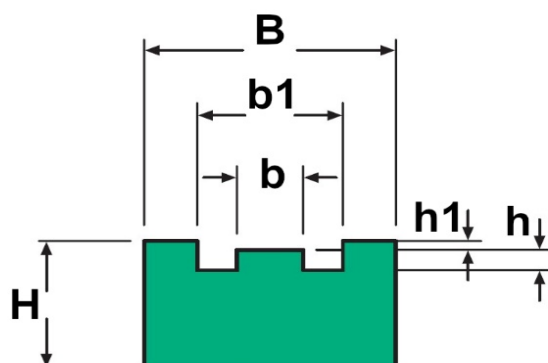

Standardní délka 2 METRY

(jiné délky na vyžádání)

Materiál: PE-UHMW vysokomolekulární polyethylen (PE-1000)

Barva: zelená

Specifická hmotnost: 0,945 g/cm<sup>3</sup>

Koeficient tření: 0,2 (P = 0,05 N/mm<sup>2</sup> – v = 0,6 m/s – t = 40°C)

Provozní teplota: -70°C +65°C

Lineární tepelná roztažnost: 2 mm každých 10°C, počínaje t = 20°C

Standard Length 2 METRES

(Other lengths on request)

Material: PE-UHMW High Molecular Weight Polyethylene (PE-1000)

Color: green

Specific weight: 0.945 g/cm<sup>3</sup>

Dynamic friction coefficient: 0.2 (P = 0.05N/mm<sup>2</sup> – v = 0.6 m/s – t = 40°C)

Operating temperature: -70°C +65°C

Linear thermal expansion: 2 mm every 10°C, starting from a temp. of 20°C

**Typ 1E - pro jednořadé válečkové řetězy dle DIN 8187 / for simple roller chains DIN 8187**

| Typ<br>Type    | Výrobní číslo<br>Product No. | Typ řetězu<br>Chain Type | B<br>(mm) | H<br>(mm) | b<br>(mm) | b1<br>(mm) | h<br>(mm) | h1<br>(mm) |  |  |  |  | m<br>(kg) |
|----------------|------------------------------|--------------------------|-----------|-----------|-----------|------------|-----------|------------|--|--|--|--|-----------|
| 1E 06B-1 25x10 | S1E010URG                    | 06B-1                    | 25        | 10        | 5,4       | 15         | 1,5       | 4,4        |  |  |  |  | 0,42      |
| 1E 08B-1 30x15 | S1E115URG                    | 08B-1                    | 30        | 15        | 7,4       | 20         | 2,2       | 7,2        |  |  |  |  | 0,79      |
| 1E 10B-1 33x20 | S1E220URG                    | 10B-1                    | 33        | 20        | 9,2       | 23         | 2,6       | 9,5        |  |  |  |  | 1,19      |
| 1E 12B-1 38x20 | S1E320URG                    | 12B-1                    | 38        | 20        | 11,3      | 28         | 2,4       | 11,1       |  |  |  |  | 1,32      |
| 1E 16B-1 51x25 | S1E425URG                    | 16B-1                    | 51        | 25        | 16,5      | 41         | 3,5       | 16,5       |  |  |  |  | 2,38      |



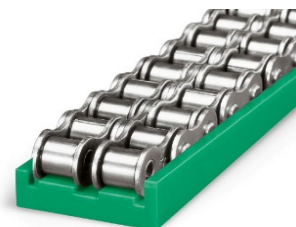
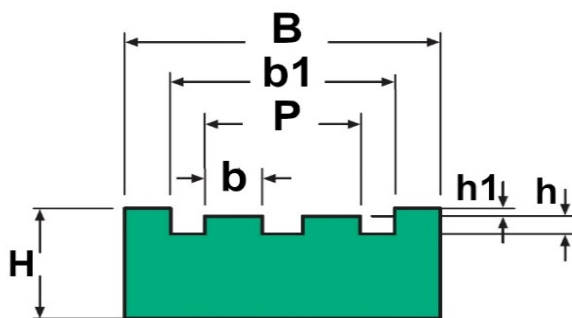

Standardní délka 2 METRY

(jiné délky na vyžádání)

Materiál: PE-UHMW vysokomolekulární polyetylen (PE-1000)

Barva: zelená

Specifická hmotnost: 0,945 g/cm<sup>3</sup>

Koeficient tření: 0,2 (P = 0,05 N/mm<sup>2</sup> – v = 0,6 m/s – t = 40°C)

Provozní teplota: -70°C +65°C

Lineární tepelná roztažnost: 2 mm každých 10°C, počínaje t = 20°C

Standard Length 2 METRES

(Other lengths on request)

Material: PE-UHMW High Molecular Weight Polyethylene (PE-1000)

Color: green

Specific weight: 0.945 g/cm<sup>3</sup>

Dynamic friction coefficient: 0.2 (P = 0.05N/mm<sup>2</sup> – v = 0.6 m/s – t = 40°C)

Operating temperature: -70°C +65°C

Linear thermal expansion: 2 mm every 10°C, starting from a temp. of 20°C

**Typ 2E - pro dvouřadé válečkové řetězy dle DIN 8187 / for double roller chains DIN 8187**

| Typ<br>Type    | Výrobní číslo<br>Product No. | Typ řetězu<br>Chain Type | B<br>(mm) | H<br>(mm) | b<br>(mm) | b1<br>(mm) | h<br>(mm) | h1<br>(mm) | P<br>(mm) |  |  |  | m<br>(kg) |
|----------------|------------------------------|--------------------------|-----------|-----------|-----------|------------|-----------|------------|-----------|--|--|--|-----------|
| 2E 06B-2 36x15 | S2E015URG                    | 06B-2                    | 36        | 15        | 5,4       | 26         | 1,5       | 4,4        | 15,8      |  |  |  | 0,93      |
| 2E 08B-2 45x20 | S2E120URG                    | 08B-2                    | 45        | 20        | 7,4       | 35         | 2,2       | 7,2        | 21,4      |  |  |  | 1,37      |
| 2E 10B-2 50x25 | S2E225URG                    | 10B-2                    | 50        | 25        | 9,2       | 40         | 2,6       | 9,5        | 25,8      |  |  |  | 1,82      |
| 2E 12B-2 56x25 | S2E325URG                    | 12B-2                    | 56        | 25        | 11,3      | 46         | 2,4       | 11,1       | 30,8      |  |  |  | 1,86      |
| 2E 16B-2 85x30 | S2E430URG                    | 16B-2                    | 85        | 30        | 16,5      | 75         | 3,5       | 16,5       | 48,4      |  |  |  | 2,55      |

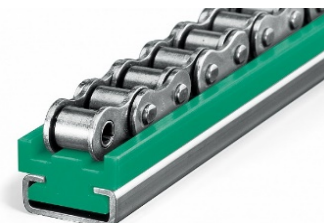
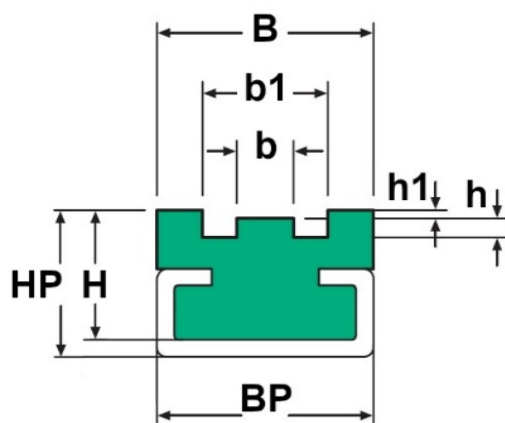

Standardní délka 2 METRY

(jiné délky na vyžádání)

Materiál: PE-UHMW vysokomolekulární polyetylen (PE-1000)

Barva: zelená

Specifická hmotnost: 0,945 g/cm<sup>3</sup>

Koeficient tření: 0,2 (P = 0,05 N/mm<sup>2</sup> – v = 0,6 m/s – t = 40°C)

Provozní teplota: -70°C +65°C

Lineární tepelná roztažnost: 2 mm každých 10°C, počínaje t = 20°C

Standard Length 2 METRES

(Other lengths on request)

Material: PE-UHMW High Molecular Weight Polyethylene (PE-1000)

Color: green

Specific weight: 0.945 g/cm<sup>3</sup>

Dynamic friction coefficient: 0.2 (P = 0.05N/mm<sup>2</sup> – v = 0.6 m/s – t = 40°C)

Operating temperature: -70°C +65°C

Linear thermal expansion: 2 mm every 10°C, starting from a temp. of 20°C

**Typ 1EC - pro jednořadé válečkové řetězy dle DIN 8187 / for simple roller chains DIN 8187**

| Typ<br>Type     | Výrobní číslo<br>Product No. | Typ řetězu<br>Chain Type | C-profil *<br>C-Profile * | B<br>(mm) | H<br>(mm) | b<br>(mm) | b1<br>(mm) | h<br>(mm) | h1<br>(mm) | BP<br>(mm) | HP<br>(mm) | m<br>(kg) |
|-----------------|------------------------------|--------------------------|---------------------------|-----------|-----------|-----------|------------|-----------|------------|------------|------------|-----------|
| 1EC 06B-1 25x18 | S1E0C3URG                    | 06B-1                    | C-3                       | 25        | 18        | 5,4       | 15         | 1,5       | 4,4        | 20         | 20         | 0,66      |
| 1EC 08B-1 30x25 | S1E1C5URG                    | 08B-1                    | C-5                       | 30        | 25        | 7,4       | 20         | 2,2       | 7,2        | 20         | 27         | 1,04      |
| 1EC 10B-1 33x30 | S1E2C5URG                    | 10B-1                    | C-5                       | 33        | 30        | 9,2       | 23         | 2,6       | 9,5        | 28         | 32         | 1,64      |
| 1EC 12B-1 38x35 | S1E3C9URG                    | 12B-1                    | C-9                       | 38        | 35        | 11,3      | 28         | 2,4       | 11,1       | 38         | 38,5       | 2,30      |
| 1EC 16B-1 51x40 | S1E4C9URG                    | 16B-1                    | C-9                       | 51        | 40        | 16,5      | 41         | 3,5       | 16,5       | 38         | 43,5       | 3,52      |

\* Upozornění: C - profily nejsou součástí. C-profil příslušné velikosti je nutno objednávat jako samostatnou položku. /

Note: C - profiles are not included. The C-profile of the appropriate size must be ordered as a separate item.

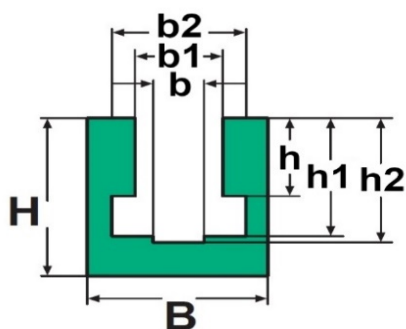

Standardní délka 2 METRY

(jiné délky na vyžádání)

Materiál: PE-UHMW vysokomolekulární polyethylen (PE-1000)

Barva: zelená

Specifická hmotnost: 0,945 g/cm<sup>3</sup>

Koeficient tření: 0,2 (P = 0,05 N/mm<sup>2</sup> – v = 0,6 m/s – t = 40°C)

Provozní teplota: -70°C +65°C

Lineární tepelná roztažnost: 2 mm každých 10°C, počínaje t = 20°C

Standard Length 2 METRES

(Other lengths on request)

Material: PE-UHMW High Molecular Weight Polyethylene (PE-1000)

Color: green

Specific weight: 0.945 g/cm<sup>3</sup>

Dynamic friction coefficient: 0.2 (P = 0.05N/mm<sup>2</sup> – v = 0.6 m/s – t = 40°C)

Operating temperature: -70°C +65°C

Linear thermal expansion: 2 mm every 10°C, starting from a temp. of 20°C

**Typ 1BL - pro jednořadé válečkové řetězy dle DIN 8187 / for simple roller chains DIN 8187**

| Typ<br>Type     | Výrobní číslo<br>Product No. | Typ řetězu<br>Chain Type | B<br>(mm) | H<br>(mm) | b<br>(mm) | b1<br>(mm) | b2<br>(mm) | h<br>(mm) | h1<br>(mm) | h2<br>(mm) |  |  | m<br>(kg) |
|-----------------|------------------------------|--------------------------|-----------|-----------|-----------|------------|------------|-----------|------------|------------|--|--|-----------|
| 1BL 06B-1 20x25 | S1BL025URG                   | 06B-1                    | 20        | 25        | 9,3       | 6,6        | 4          | 5,6       | 8,7        | 10         |  |  | 0,80      |
| 1BL 08B-1 24x30 | S1BL130URG                   | 08B-1                    | 24        | 30        | 12,8      | 8,7        | 5          | 7,6       | 11,5       | 13,5       |  |  | 1,14      |
| 1BL 10B-1 30x35 | S1BL235URG                   | 10B-1                    | 30        | 35        | 15,4      | 10,4       | 6          | 9,5       | 13,5       | 14,8       |  |  | 1,65      |
| 1BL 12B-1 40x35 | S1BL335URG                   | 12B-1                    | 40        | 35        | 16,9      | 12,3       | 7          | 11,5      | 15,9       | 17,5       |  |  | 2,20      |
| 1BL 16B-1 40x45 | S1BL440URG                   | 16B-1                    | 40        | 45        | 24,4      | 16,1       | 9          | 16,1      | 25,7       | 26,8       |  |  | 2,44      |
| 1BL 20B-1 50x50 | S1BL550URG                   | 20B-1                    | 50        | 50        | 27,5      | 19,3       | 11         | 19,4      | 29,3       | 31,2       |  |  | 3,43      |
| 1BL 24B-1 60x60 | S1BL660URG                   | 24B-1                    | 60        | 60        | 36,5      | 25,7       | 16         | 25,2      | 38,2       | 40,1       |  |  | 4,65      |
| 1BL 28B-1 60x70 | S1BL770URG                   | 28B-1                    | 60        | 70        | 41,5      | 28,3       | 17         | 30,8      | 46,9       | 48,9       |  |  | 4,93      |
| 1BL 32B-1 70x75 | S1BL875URG                   | 32B-1                    | 70        | 75        | 44,5      | 29,6       | 19         | 30,8      | 47,3       | 53         |  |  | 6,52      |

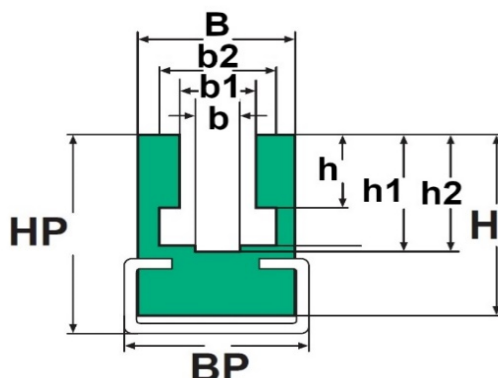

Standardní délka 2 METRY

(jiné délky na vyžádání)

Materiál: PE-UHMW vysokomolekulární polyetylen (PE-1000)

Barva: zelená

Specifická hmotnost: 0,945 g/cm<sup>3</sup>

Koeficient tření: 0,2 (P = 0,05 N/mm<sup>2</sup> – v = 0,6 m/s – t = 40°C)

Provozní teplota: -70°C +65°C

Lineární tepelná roztažnost: 2 mm každých 10°C, počínaje t = 20°C

Standard Length 2 METRES

(Other lengths on request)

Material: PE-UHMW High Molecular Weight Polyethylene (PE-1000)

Color: green

Specific weight: 0.945 g/cm<sup>3</sup>

Dynamic friction coefficient: 0.2 (P = 0.05N/mm<sup>2</sup> – v = 0.6 m/s – t = 40°C)

Operating temperature: -70°C +65°C

Linear thermal expansion: 2 mm every 10°C, starting from a temp. of 20°C

**Typ 1BLC - pro jednořadé válečkové řetězy dle DIN 8187 / for simple roller chains DIN 8187**

| Typ                | Výrobní číslo | Typ řetězu | C-profil*   | B    | H    | b    | b1   | b2   | h    | h1   | h2   | BP   | HP   | m    |
|--------------------|---------------|------------|-------------|------|------|------|------|------|------|------|------|------|------|------|
| Type               | Product No.   | Chain Type | C-Profile * | (mm) | (mm) | (mm) | (mm) | (mm) | (mm) | (mm) | (mm) | (mm) | (mm) | (kg) |
| 1BLC 06B-1 20x17,5 | S1BL0C3URG    | 06B-1      | C-3         | 20   | 17,5 | 4    | 6,6  | 9,3  | 5,6  | 8,7  | 9,9  | 20   | 21   | 0,8  |
| 1BLC 08B-1 24x27,5 | S1BL1C5URG    | 08B-1      | C-5         | 24   | 27,5 | 5    | 8,7  | 12,8 | 7,6  | 11,5 | 12,7 | 28   | 32   | 0,8  |
| 1BLC 10B-1 24x27,5 | S1BL2C5URG    | 10B-1      | C-5         | 24   | 27,5 | 6    | 10,4 | 15,4 | 9,5  | 13,5 | 14,8 | 28   | 32   | 0,8  |
| 1BLC 12B-1 33x34   | S1BL3C9URG    | 12B-1      | C-9         | 33   | 34   | 7    | 12,3 | 16,9 | 11,5 | 15,9 | 17,5 | 38   | 42   | 2,2  |
| 1BLC 16B-1 38x45   | S1BL4C9URG    | 16B-1      | C-9         | 38   | 45   | 9    | 16,1 | 24,4 | 16,9 | 25,7 | 26,8 | 38   | 49   | 2,0  |

\* Upozornění: C - profily nejsou součástí. C-profil příslušné velikosti je nutno objednávat jako samostatnou položku. /

Note: C - profiles are not included. The C-profile of the appropriate size must be ordered as a separate item.

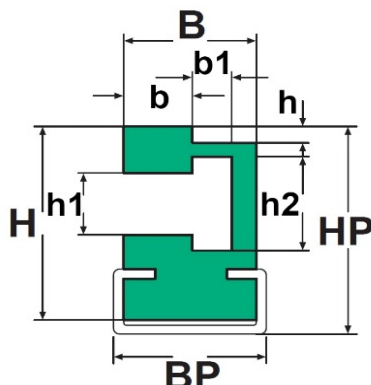

Standardní délka 2 METRY

(jiné délky na vyžádání)

Materiál: PE-UHMW vysokomolekulární polyethylen (PE-1000)

Barva: zelená

Specifická hmotnost: 0,945 g/cm<sup>3</sup>

Koeficient tření: 0,2 (P = 0,05 N/mm<sup>2</sup> – v = 0,6 m/s – t = 40°C)

Provozní teplota: -70°C +65°C

Lineární tepelná roztažnost: 2 mm každých 10°C, počínaje t = 20°C

Standard Length 2 METRES

(Other lengths on request)

Material: PE-UHMW High Molecular Weight Polyethylene (PE-1000)

Color: green

Specific weight: 0.945 g/cm<sup>3</sup>

Dynamic friction coefficient: 0.2 (P = 0.05N/mm<sup>2</sup> – v = 0.6 m/s – t = 40°C)

Operating temperature: -70°C +65°C

Linear thermal expansion: 2 mm every 10°C, starting from a temp. of 20°C

### Typ 1CB - pro jednořadé válečkové řetězy dle DIN 8187 / for simple roller chains DIN 8187

| Typ                 | Výrobní číslo | Typ řetězu | C-<br>profil* | B    | H    | b    | b1   | h    | h1   | h2   | BP   | HP   | m    |
|---------------------|---------------|------------|---------------|------|------|------|------|------|------|------|------|------|------|
| Type                | Product No.   | Chain Type | Profile       | (mm) | (mm) | (mm) | (mm) | (mm) | (mm) | (mm) | (mm) | (mm) | (kg) |
| 1CB 06B-1 20x26,4   | S1CB0C3URG    | 06B-1      | C-3           | 20   | 26,4 | 5,4  | 4,3  | 1,4  | 6,6  | 9,3  | 20   | 28,7 | 0,51 |
| 1CB 08B-1 20x28     | S1CB1C3URG    | 08B-1      | C-3           | 20   | 28   | 7,6  | 5,1  | 2    | 8,7  | 12,8 | 20   | 30,5 | 0,61 |
| 1CB 10B-1 20x34,1   | S1CB2C3URG    | 10B-1      | C-3           | 20   | 34,1 | 9,5  | 5,3  | 2,5  | 10,4 | 15,4 | 20   | 36   | 0,58 |
| 1CB 12B-1 24x38,5   | S1CB3C5URG    | 12B-1      | C-5           | 24   | 38,5 | 11,5 | 6    | 2,3  | 12,3 | 16,9 | 28   | 41,5 | 0,80 |
| 1CB 16B-1 33,5x52,4 | S1CB4C9URG    | 16B-1      | C-9           | 33,5 | 52,4 | 16,9 | 10   | 4,1  | 16,1 | 24,4 | 38   | 61,5 | 1,23 |

\* Upozornění: C - profily nejsou součástí. C-profil příslušné velikosti je nutno objednávat jako samostatnou položku. /

Note: C - profiles are not included. The C-profile of the appropriate size must be ordered as a separate item.

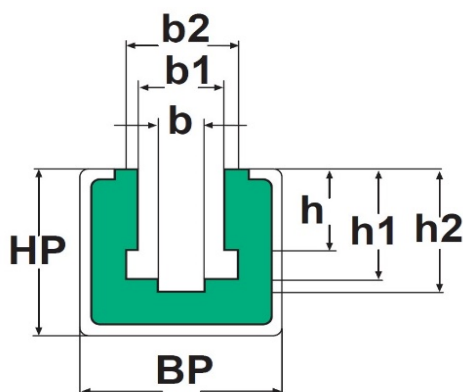

Standardní délka 2 METRY

(jiné délky na vyžádání)

Materiál: PE-UHMW vysokomolekulární polyetylen (PE-1000)

Barva: zelená

Specifická hmotnost: 0,945 g/cm<sup>3</sup>

Koeficient tření: 0,2 (P = 0,05 N/mm<sup>2</sup> – v = 0,6 m/s – t = 40°C)

Provozní teplota: -70°C +65°C

Lineární tepelná roztažnost: 2 mm každých 10°C, počínaje t = 20°C

Standard Length 2 METRES

(Other lengths on request)

Material: PE-UHMW High Molecular Weight Polyethylene (PE-1000)

Color: green

Specific weight: 0.945 g/cm<sup>3</sup>

Dynamic friction coefficient: 0.2 (P = 0.05N/mm<sup>2</sup> – v = 0.6 m/s – t = 40°C)

Operating temperature: -70°C +65°C

Linear thermal expansion: 2 mm every 10°C, starting from a temp. of 20°C

**Typ 1CP - pro jednořadé válečkové řetězy dle DIN 8187 / for simple roller chains DIN 8187**

| Typ<br>Type | Výrobní číslo<br>Product No. | Typ řetězu<br>Chain Type | C-profil *<br>C-Profile * | b<br>(mm) | b1<br>(mm) | b2<br>(mm) | h<br>(mm) | h1<br>(mm) | h2<br>(mm) | BP<br>(mm) | HP<br>(mm) | m<br>(kg) |
|-------------|------------------------------|--------------------------|---------------------------|-----------|------------|------------|-----------|------------|------------|------------|------------|-----------|
| 1CP 06B-1   | S1CP0C10URG                  | 06B-1                    | C-10                      | 4         | 6,6        | 9,3        | 5,6       | 8,7        | 10         | 30         | 24         | 0,26      |
| 1CP 08B-1   | S1CP1C10URG                  | 08B-1                    | C-10                      | 5         | 8,7        | 13,5       | 7,6       | 11,5       | 13,5       | 30         | 24         | 0,27      |
| 1CP 10B-1   | S1CP2C10URG                  | 10B-1                    | C-10                      | 6         | 10,4       | 15,4       | 9,5       | 13,5       | 14,8       | 30         | 24         | 0,28      |
| 1CP 12B-1   | S1CP3C10URG                  | 12B-1                    | C-10                      | 7         | 12,3       | 17,5       | 11,5      | 15,9       | 17,5       | 30         | 24         | 0,36      |
| 1CP 16B-1   | S1CP4C11URG                  | 16B-1                    | C-11                      | 9         | 16,1       | 24,4       | 16,1      | 25,7       | 26,8       | 45         | 40         | 0,60      |

\* Upozornění: C - profily nejsou součástí. C-profil příslušné velikosti je nutno objednávat jako samostatnou položku. /

Note: C - profiles are not included. The C-profile of the appropriate size must be ordered as a separate item.

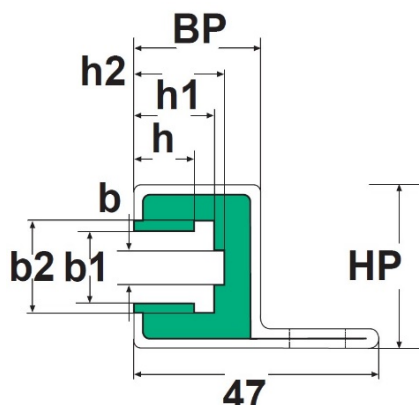

Standardní délka 2 METRY

(jiné délky na vyžádání)

Materiál: PE-UHMW vysokomolekulární polyetylen (PE-1000)

Barva: zelená

Specifická hmotnost: 0,945 g/cm<sup>3</sup>

Koeficient tření: 0,2 (P = 0,05 N/mm<sup>2</sup> – v = 0,6 m/s – t = 40°C)

Provozní teplota: -70°C +65°C

Lineární tepelná roztažnost: 2 mm každých 10°C, počínaje t = 20°C

Standard Length 2 METRES

(Other lengths on request)

Material: PE-UHMW High Molecular Weight Polyethylene (PE-1000)

Color: green

Specific weight: 0.945 g/cm<sup>3</sup>

Dynamic friction coefficient: 0.2 (P = 0.05N/mm<sup>2</sup> – v = 0.6 m/s – t = 40°C)

Operating temperature: -70°C +65°C

Linear thermal expansion: 2 mm every 10°C, starting from a temp. of 20°C

**Typ 1BKC14 - pro jednořadé válečkové řetězy dle DIN 8187 / for simple roller chains DIN 8187**

| Typ<br>Type  | Výrobní číslo<br>Product No. | Typ řetězu<br>Chain Type | C-profil *<br>C-Profile * | b<br>(mm) | b1<br>(mm) | b2<br>(mm) | h<br>(mm) | h1<br>(mm) | h2<br>(mm) | BP<br>(mm) | HP<br>(mm) | m<br>(kg) |
|--------------|------------------------------|--------------------------|---------------------------|-----------|------------|------------|-----------|------------|------------|------------|------------|-----------|
| 1BKC14 06B-1 | S1BK0C14URG                  | 06B-1                    | C-14                      | 4         | 6,6        | 9,3        | 5,6       | 8,7        | 10         | 25         | 31         | 0,26      |
| 1BKC14 08B-1 | S1BK1C14URG                  | 08B-1                    | C-14                      | 5         | 8,7        | 12,8       | 7,6       | 11,5       | 13,5       | 25         | 31         | 0,27      |
| 1BKC14 10B-1 | S1BK2C14URG                  | 10B-1                    | C-14                      | 6         | 10,4       | 15,4       | 9,5       | 13,5       | 14,8       | 25         | 31         | 0,28      |
| 1BKC14 12B-1 | S1BK3C14URG                  | 12B-1                    | C-14                      | 7         | 12,3       | 16,9       | 11,5      | 15,9       | 17,5       | 25         | 31         | 0,36      |

\* Upozornění: C - profily nejsou součástí. C-profil příslušné velikosti je nutno objednávat jako samostatnou položku. /

Note: C - profiles are not included. The C-profile of the appropriate size must be ordered as a separate item.

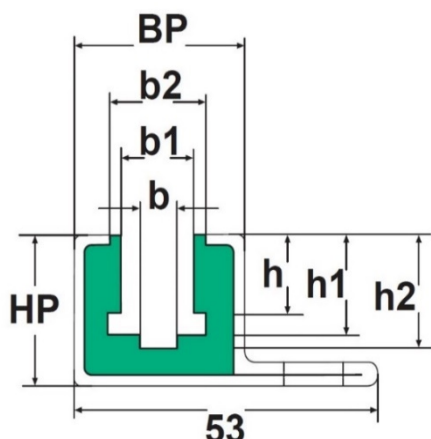

Standardní délka 2 METRY

(jiné délky na vyžádání)

Materiál: PE-UHMW vysokomolekulární polyetylen (PE-1000)

Barva: zelená

Specifická hmotnost: 0,945 g/cm<sup>3</sup>

Koeficient tření: 0,2 (P = 0,05 N/mm<sup>2</sup> – v = 0,6 m/s – t = 40°C)

Provozní teplota: -70°C +65°C

Lineární tepelná roztažnost: 2 mm každých 10°C, počínaje t = 20°C

Standard Length 2 METRES

(Other lengths on request)

Material: PE-UHMW High Molecular Weight Polyethylene (PE-1000)

Color: green

Specific weight: 0.945 g/cm<sup>3</sup>

Dynamic friction coefficient: 0.2 (P = 0.05N/mm<sup>2</sup> – v = 0.6 m/s – t = 40°C)

Operating temperature: -70°C +65°C

Linear thermal expansion: 2 mm every 10°C, starting from a temp. of 20°C

**Typ 1BKC15 - pro jednořadé válečkové řetězy dle DIN 8187 / for simple roller chains DIN 8187**

| Typ<br>Type  | Výrobní číslo<br>Product No. | Typ řetězu<br>Chain Type | C-profil *<br>C-Profile * | b<br>(mm) | b1<br>(mm) | b2<br>(mm) | h<br>(mm) | h1<br>(mm) | h2<br>(mm) | BP<br>(mm) | HP<br>(mm) | m<br>(kg) |
|--------------|------------------------------|--------------------------|---------------------------|-----------|------------|------------|-----------|------------|------------|------------|------------|-----------|
| 1BKC15 06B-1 | S1BK0C15URG                  | 06B-1                    | C-15                      | 4         | 6,6        | 9,3        | 5,6       | 8,7        | 10         | 31         | 25         | 0,26      |
| 1BKC15 08B-1 | S1BK1C15URG                  | 08B-1                    | C-15                      | 5         | 8,7        | 12,8       | 7,6       | 11,5       | 13,5       | 31         | 25         | 0,27      |
| 1BKC15 10B-1 | S1BK2C15URG                  | 10B-1                    | C-15                      | 6         | 10,4       | 15,4       | 9,5       | 13,5       | 14,8       | 31         | 25         | 0,28      |
| 1BKC15 12B-1 | S1BK3C15URG                  | 12B-1                    | C-15                      | 7         | 12,3       | 16,9       | 11,5      | 15,9       | 17,5       | 31         | 25         | 0,36      |

\* Upozornění: C - profily nejsou součástí. C-profil příslušné velikosti je nutno objednávat jako samostatnou položku. /

Note: C - profiles are not included. The C-profile of the appropriate size must be ordered as a separate item.



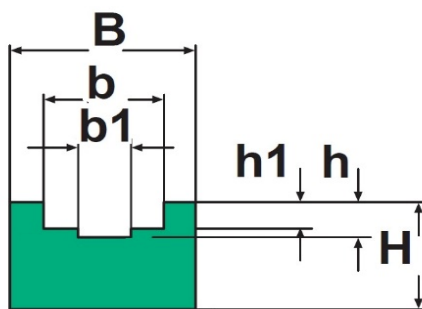

Standardní délka 2 METRY

(jiné délky na vyžádání)

Materiál: PE-UHMW vysokomolekulární polyethylen (PE-1000)

Barva: zelená

Specifická hmotnost: 0,945 g/cm<sup>3</sup>

Koeficient tření: 0,2 (P = 0,05 N/mm<sup>2</sup> – v = 0,6 m/s – t = 40°C)

Provozní teplota: -70°C +65°C

Lineární tepelná roztažnost: 2 mm každých 10°C, počínaje t = 20°C

Standard Length 2 METRES

(Other lengths on request)

Material: PE-UHMW High Molecular Weight Polyethylene (PE-1000)

Color: green

Specific weight: 0.945 g/cm<sup>3</sup>

Dynamic friction coefficient: 0.2 (P = 0.05N/mm<sup>2</sup> – v = 0.6 m/s – t = 40°C)

Operating temperature: -70°C +65°C

Linear thermal expansion: 2 mm every 10°C, starting from a temp. of 20°C

**Typ 1U - pro jednořadé válečkové řetězy dle DIN 8187 / for simple roller chains DIN 8187**

| Typ<br>Type    | Výrobní číslo<br>Product No. | Typ řetězu<br>Chain Type | B<br>(mm) | H<br>(mm) | b<br>(mm) | b1<br>(mm) | h<br>(mm) | h1<br>(mm) |  |  |  |  | m<br>(kg) |
|----------------|------------------------------|--------------------------|-----------|-----------|-----------|------------|-----------|------------|--|--|--|--|-----------|
| 1U 06B-1 20x15 | S1U015URG                    | 06B-1                    | 20        | 15        | 9,2       | 4          | 4,2       | 2,8        |  |  |  |  | 0,54      |
| 1U 08B-1 25x15 | S1U115URG                    | 08B-1                    | 25        | 15        | 12,7      | 5          | 4,8       | 3,5        |  |  |  |  | 0,63      |
| 1U 10B-1 25x15 | S1U215URG                    | 10B-1                    | 25        | 15        | 15,2      | 6          | 5,1       | 3,6        |  |  |  |  | 0,61      |
| 1U 12B-1 25x20 | S1U320URG                    | 12B-1                    | 25        | 20        | 16,7      | 7          | 5,7       | 3,9        |  |  |  |  | 0,83      |
| 1U 16B-1 35x20 | S1U425URG                    | 16B-1                    | 35        | 20        | 24,4      | 9          | 10        | 8,4        |  |  |  |  | 1,27      |

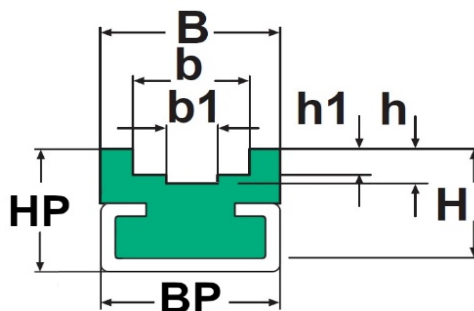

Standardní délka 2 METRY

(jiné délky na vyžádání)

Materiál: PE-UHMW vysokomolekulární polyetylen (PE-1000)

Barva: zelená

Specifická hmotnost: 0,945 g/cm<sup>3</sup>

Koeficient tření: 0,2 (P = 0,05 N/mm<sup>2</sup> – v = 0,6 m/s – t = 40°C)

Provozní teplota: -70°C +65°C

Lineární tepelná roztažnost: 2 mm každých 10°C, počínaje t = 20°C

Standard Length 2 METRES

(Other lengths on request)

Material: PE-UHMW High Molecular Weight Polyethylene (PE-1000)

Color: green

Specific weight: 0.945 g/cm<sup>3</sup>

Dynamic friction coefficient: 0.2 (P = 0.05N/mm<sup>2</sup> – v = 0.6 m/s – t = 40°C)

Operating temperature: -70°C +65°C

Linear thermal expansion: 2 mm every 10°C, starting from a temp. of 20°C

### Typ 1UC - pro jednořadé válečkové řetězy dle DIN 8187 / for simple roller chains DIN 8187

| Typ<br>Type     | Výrobní číslo<br>Product No. | Typ řetězu<br>Chain Type | C-profil *<br>C-Profile * | B<br>(mm) | H<br>(mm) | b<br>(mm) | b1<br>(mm) | h<br>(mm) | h1<br>(mm) | BP<br>(mm) | HP<br>(mm) | m<br>(kg) |
|-----------------|------------------------------|--------------------------|---------------------------|-----------|-----------|-----------|------------|-----------|------------|------------|------------|-----------|
| 1UC 06B-1 20x15 | S1U0C315URG                  | 06B-1                    | C-3                       | 20        | 15        | 9,2       | 4          | 4,2       | 2,8        | 20         | 18         | 0,54      |
| 1UC 08B-1 25x15 | S1U1C315URG                  | 08B-1                    | C-3                       | 25        | 15        | 12,7      | 5          | 4,8       | 3,5        | 20         | 18         | 0,63      |
| 1UC 10B-1 25x15 | S1U2C315URG                  | 10B-1                    | C-3                       | 25        | 15        | 15,2      | 6          | 5,1       | 3,6        | 20         | 18         | 0,61      |
| 1UC 12B-1 25x20 | S1U3C320URG                  | 12B-1                    | C-3                       | 25        | 20        | 16,7      | 7          | 5,7       | 3,9        | 20         | 23         | 0,83      |
| 1UC 16B-1 35x20 | S1U4C525URG                  | 16B-1                    | C-5                       | 35        | 20        | 24,4      | 8          | 10        | 8,4        | 28         | 28         | 1,27      |

\* Upozornění: C - profily nejsou součástí. C-profil příslušné velikosti je nutno objednávat jako samostatnou položku. /

Note: C - profiles are not included. The C-profile of the appropriate size must be ordered as a separate item.

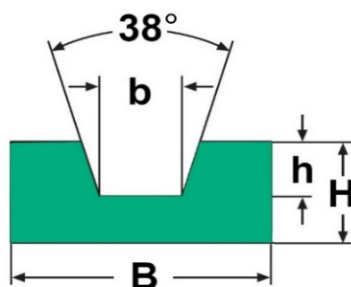

Standardní délka 2 METRY

(jiné délky na vyžádání)

Materiál: PE-UHMW vysokomolekulární polyethylen (PE-1000)

Barva: zelená

Specifická hmotnost: 0,945 g/cm<sup>3</sup>

Koeficient tření: 0,2 (P = 0,05 N/mm<sup>2</sup> – v = 0,6 m/s – t = 40°C)

Provozní teplota: -70°C +65°C

Lineární tepelná roztažnost: 2 mm každých 10°C, počínaje t = 20°C

Standard Length 2 METRES

(Other lengths on request)

Material: PE-UHMW High Molecular Weight Polyethylene (PE-1000)

Color: green

Specific weight: 0.945 g/cm<sup>3</sup>

Dynamic friction coefficient: 0.2 (P = 0.05N/mm<sup>2</sup> – v = 0.6 m/s – t = 40°C)

Operating temperature: -70°C +65°C

Linear thermal expansion: 2 mm every 10°C, starting from a temp. of 20°C

**Typ V - pro klínové řemeny / for V - belts**

| Typ<br>Type    | Výrobní číslo<br>Product No. | Typ řemenu<br>Belt Type | B<br>(mm) | H<br>(mm) | h<br>(mm) | d<br>(mm) |  |  |  |  |  |  | m<br>(kg) |
|----------------|------------------------------|-------------------------|-----------|-----------|-----------|-----------|--|--|--|--|--|--|-----------|
| V (10/Z) 20x10 | SV10URG                      | Z/10                    | 20        | 10        | 3         | 6,5       |  |  |  |  |  |  | 0,35      |
| V (13/A) 20x12 | SV13URG                      | A/13                    | 20        | 12        | 5         | 8         |  |  |  |  |  |  | 0,35      |
| V (SPB) 25x15  | SV15URG                      | SPB                     | 25        | 15        | 8         | 9,5       |  |  |  |  |  |  | 0,55      |
| V (17/B) 30x15 | SV17URG                      | B/17                    | 30        | 15        | 8         | 10,5      |  |  |  |  |  |  | 0,68      |
| V (22/C) 35x20 | SV22URG                      | C/22                    | 35        | 20        | 11        | 13,5      |  |  |  |  |  |  | 1,02      |
| V (32/D) 40x25 | SV32URG                      | D/32                    | 40        | 25        | 13        | 19        |  |  |  |  |  |  | 1,53      |

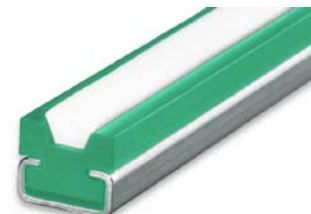
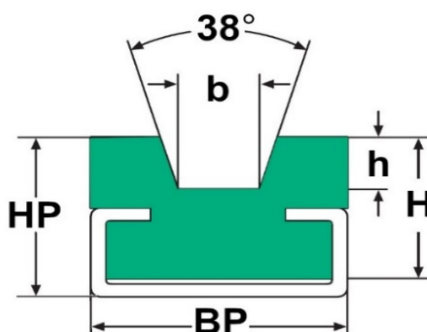

Standardní délka 2 METRY

(jiné délky na vyžádání)

Materiál: PE-UHMW vysokomolekulární polyetylen (PE-1000)

Barva: zelená

Specifická hmotnost: 0,945 g/cm<sup>3</sup>

Koeficient tření: 0,2 (P = 0,05 N/mm<sup>2</sup> – v = 0,6 m/s – t = 40°C)

Provozní teplota: -70°C +65°C

Lineární tepelná roztažnost: 2 mm každých 10°C, počínaje t = 20°C

Standard Length 2 METRES

(Other lengths on request)

Material: PE-UHMW High Molecular Weight Polyethylene (PE-1000)

Color: green

Specific weight: 0.945 g/cm<sup>3</sup>

Dynamic friction coefficient: 0.2 (P = 0.05N/mm<sup>2</sup> – v = 0.6 m/s – t = 40°C)

Operating temperature: -70°C +65°C

Linear thermal expansion: 2 mm every 10°C, starting from a temp. of 20°C

**Typ VC - pro klínové řemeny / for V - belts**

| Typ<br>Type     | Výrobní číslo<br>Product No. | Typ řemenu<br>Belt Type | C-profil *<br>C-Profile * | B<br>(mm) | H<br>(mm) | b<br>(mm) | h<br>(mm) | BP<br>(mm) | HP<br>(mm) |  |  | m<br>(kg) |
|-----------------|------------------------------|-------------------------|---------------------------|-----------|-----------|-----------|-----------|------------|------------|--|--|-----------|
| VC (10/Z) 20x15 | SV10C3URG                    | Z/10                    | C-3                       | 20        | 15        | 6,5       | 3         | 20         | 17         |  |  | 0,30      |
| VC (13/A) 20x15 | SV13C3URG                    | A/13                    | C-3                       | 20        | 15        | 8         | 5         | 20         | 17         |  |  | 0,28      |
| VC (SPB) 25x20  | SV15C5URG                    | SPB                     | C-5                       | 25        | 20        | 9,5       | 8         | 28         | 24         |  |  | 0,62      |
| VC (17/B) 30x20 | SV17C5URG                    | B/17                    | C-5                       | 30        | 20        | 10,5      | 8         | 28         | 24         |  |  | 0,73      |
| VC (22/C) 35x25 | SV22C9URG                    | C/22                    | C-9                       | 35        | 25        | 13,5      | 11        | 38         | 32         |  |  | 1,15      |
| VC (32/D) 40x25 | SV32C9URG                    | D/32                    | C-9                       | 40        | 25        | 19        | 13        | 38         | 35         |  |  | 1,13      |

\* **Upozornění: C - profily nejsou součástí. C-profil příslušné velikosti je nutno objednávat jako samostatnou položku. /**

Note: C - profiles are not included. The C-profile of the appropriate size must be ordered as a separate item.

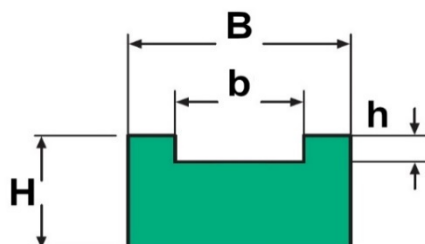

Standardní délka 2 METRY

(jiné délky na vyzádání)

Materiál: PE-UHMW vysokomolekulární polyethylen (PE-1000)

Barva: zelená

Specifická hmotnost: 0,945 g/cm<sup>3</sup>

Koeficient tření: 0,2 (P = 0,05 N/mm<sup>2</sup> – v = 0,6 m/s – t = 40°C)

Provozní teplota: -70°C +65°C

Lineární tepelná roztažnost: 2 mm každých 10°C, počínaje t = 20°C

Standard Length 2 METRES

(Other lengths on request)

Material: PE-UHMW High Molecular Weight Polyethylene (PE-1000)

Color: green

Specific weight: 0.945 g/cm<sup>3</sup>

Dynamic friction coefficient: 0.2 (P = 0.05N/mm<sup>2</sup> – v = 0.6 m/s – t = 40°C)

Operating temperature: -70°C +65°C

Linear thermal expansion: 2 mm every 10°C, starting from a temp. of 20°C

### Typ F - pro ozubené řemeny / for timing belts

| Typ<br>Type      | Výrobní číslo<br>Product No. | Typ řemenu<br>Belt Type | Š.řem.<br>Width | tl.řem.<br>Thickn. | B<br>(mm) | H<br>(mm) | b<br>(mm) | h<br>(mm) |  |  |  |  | m<br>(kg) |
|------------------|------------------------------|-------------------------|-----------------|--------------------|-----------|-----------|-----------|-----------|--|--|--|--|-----------|
| F (L050) 20x15   | SF1301URG                    | L                       | 12,7            | 3,6                | 20        | 15        | 14,2      | 2,5       |  |  |  |  | 0,58      |
| F (H050) 20x15   | SF1302URG                    | H                       | 12,7            | 4,3                | 20        | 15        | 14,2      | 2,5       |  |  |  |  | 0,78      |
| F (5M-15) 25x15  | SF1501URG                    | HTD 5M                  | 15              | 3,8                | 25        | 15        | 16,5      | 2,5       |  |  |  |  | 0,87      |
| F (8M-15) 25x15  | SF1502URG                    | HTD 8M                  | 15              | 5,4                | 25        | 15        | 16,5      | 3,5       |  |  |  |  | 1,41      |
| F (T5-16) 25x10  | SF1601URG                    | T5                      | 16              | 2,2                | 25        | 10        | 17,5      | 1,6       |  |  |  |  | 0,89      |
| F (AT5-16) 25x10 | SF1602URG                    | AT5                     | 16              | 2,7                | 25        | 10        | 17,5      | 2         |  |  |  |  | 1,15      |
| F (T10-16) 25x15 | SF1603URG                    | T10/AT10                | 16              | 4,5                | 25        | 15        | 17,5      | 2,5       |  |  |  |  | 1,33      |
| F (L075) 28x15   | SF1901URG                    | L                       | 19,05           | 3,6                | 28        | 15        | 21        | 2,5       |  |  |  |  | 1,84      |
| F (H075) 28x15   | SF1902URG                    | H                       | 19,05           | 4,3                | 28        | 15        | 21        | 2,5       |  |  |  |  | 2,56      |
| F (8M-20) 28x15  | SF2001URG                    | HTD 8M                  | 20              | 5,4                | 28        | 15        | 21,5      | 3,5       |  |  |  |  | 3,26      |
| F (T5-25) 35x10  | SF2501URG                    | T5                      | 25              | 2,2                | 35        | 10        | 26,5      | 1,6       |  |  |  |  | 1,5       |
| F (AT5-25) 35x10 | SF2502URG                    | AT5                     | 25              | 2,7                | 35        | 10        | 26,5      | 2         |  |  |  |  | 1,77      |
| F (T10-25) 35x15 | SF2503URG                    | T10/AT10                | 25              | 4,5                | 35        | 15        | 26,5      | 2,5       |  |  |  |  | 2,46      |
| F (T20-25) 35x20 | SF2504URG                    | T20/AT20                | 25              | 8                  | 35        | 20        | 26,5      | 6         |  |  |  |  | 3,7       |
| F (5M-25) 35x15  | SF2505URG                    | HTD 5M                  | 25              | 3,8                | 35        | 15        | 26,5      | 2,5       |  |  |  |  | 4,93      |
| F (8M-25) 35x15  | SF2506URG                    | HTD 8M                  | 25              | 5,4                | 35        | 15        | 26,5      | 3,5       |  |  |  |  | 4,95      |
| F (L100) 35x15   | SF2507URG                    | L                       | 25,4            | 3,6                | 35        | 15        | 27        | 2,5       |  |  |  |  | 5,1       |
| F (H100) 35x15   | SF2508URG                    | H                       | 25,4            | 4,3                | 35        | 15        | 27        | 2,5       |  |  |  |  | 5,12      |
| F (XH100) 35x20  | SF2509URG                    | XH                      | 25,4            | 11,2               | 35        | 20        | 27        | 8         |  |  |  |  | 5,25      |
| F (8M-30) 40x15  | SF3001URG                    | HTD 8M                  | 30              | 5,4                | 40        | 15        | 31,5      | 3,5       |  |  |  |  | 5,35      |
| F (T5-32) 40x10  | SF3201URG                    | T5                      | 32              | 2,2                | 40        | 10        | 33,5      | 1,6       |  |  |  |  | 5,45      |
| F (AT5-32) 40x10 | SF3202URG                    | AT5                     | 32              | 2,7                | 40        | 10        | 33,5      | 2         |  |  |  |  | 5,55      |
| F (T10-32) 40x15 | SF3203URG                    | T10/AT10                | 32              | 4,5                | 40        | 15        | 33,5      | 2,5       |  |  |  |  | 5,65      |
| F (T20-32) 40x20 | SF3204URG                    | T20/AT20                | 32              | 8                  | 40        | 20        | 33,5      | 6         |  |  |  |  | 5,7       |
| F (H150) 50x15   | SF3801URG                    | H                       | 38,1            | 3,8                | 50        | 15        | 40        | 2,5       |  |  |  |  | 5,8       |
| F (T5-50) 60x10  | SF5001URG                    | T5                      | 50              | 2,2                | 60        | 10        | 51,5      | 1,6       |  |  |  |  | 1,33      |
| F (AT5-50) 60x10 | SF5002URG                    | AT5                     | 50              | 2,7                | 60        | 10        | 51,5      | 2         |  |  |  |  | 1,84      |
| F (T10-50) 60x15 | SF5003URG                    | T10/AT10                | 50              | 4,5                | 60        | 15        | 51,5      | 2,5       |  |  |  |  | 2,56      |

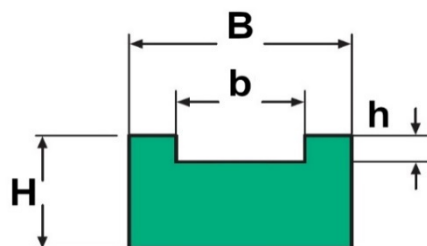

Standardní délka 2 METRY

(jiné délky na vyzádání)

Materiál: PE-UHMW vysokomolekulární polyethylen (PE-1000)

Barva: zelená

Specifická hmotnost: 0,945 g/cm<sup>3</sup>

Koeficient tření: 0,2 (P = 0,05 N/mm<sup>2</sup> – v = 0,6 m/s – t = 40°C)

Provozní teplota: -70°C +65°C

Lineární tepelná roztažnost: 2 mm každých 10°C, počínaje t = 20°C

Standard Length 2 METRES

(Other lengths on request)

Material: PE-UHMW High Molecular Weight Polyethylene (PE-1000)

Color: green

Specific weight: 0.945 g/cm<sup>3</sup>

Dynamic friction coefficient: 0.2 (P = 0.05N/mm<sup>2</sup> – v = 0.6 m/s – t = 40°C)

Operating temperature: -70°C +65°C

Linear thermal expansion: 2 mm every 10°C, starting from a temp. of 20°C

### Typ F - pro ozubené řemeny / for timing belts

| Typ<br>Type        | Výrobní číslo<br>Product No. | Typ řemenu<br>Belt Type | Šířka<br>Widht | TL.řem.<br>Thickn. | B<br>(mm) | H<br>(mm) | b<br>(mm) | h<br>(mm) |  |  |  |  | m<br>(kg) |
|--------------------|------------------------------|-------------------------|----------------|--------------------|-----------|-----------|-----------|-----------|--|--|--|--|-----------|
| F (T20-50) 60x20   | SF5004URG                    | T20/AT20                | 50             | 8                  | 60        | 20        | 51,5      | 6         |  |  |  |  | 3,26      |
| F (5M-50) 60x15    | SF5005URG                    | HTD 5M                  | 50             | 3,8                | 60        | 15        | 51,5      | 2,5       |  |  |  |  | 1,5       |
| F (8M-50) 60x15    | SF5006URG                    | HTD 8M                  | 50             | 5,4                | 60        | 15        | 51,5      | 3,5       |  |  |  |  | 1,77      |
| F (L200) 60x15     | SF5101URG                    | L                       | 50,8           | 3,6                | 60        | 15        | 53        | 2,5       |  |  |  |  | 2,46      |
| F (H200) 60x15     | SF5102URG                    | H                       | 50,8           | 4,3                | 60        | 15        | 53        | 2,5       |  |  |  |  | 3,7       |
| F (XH200) 60x20    | SF5103URG                    | XH                      | 50,8           | 11,2               | 60        | 20        | 53        | 8         |  |  |  |  | 4,93      |
| F (14M-55) 65x20   | SF5501URG                    | HTD 14M                 | 55             | 10                 | 65        | 20        | 56,5      | 7         |  |  |  |  | 4,95      |
| F (T5-75) 85x10    | SF7501URG                    | T5                      | 75             | 2,2                | 85        | 10        | 76,5      | 1,6       |  |  |  |  | 5,1       |
| F (AT5-75) 85x10   | SF7502URG                    | AT5                     | 75             | 2,7                | 85        | 10        | 76,5      | 2         |  |  |  |  | 5,12      |
| F (T10-75) 85x15   | SF7503URG                    | T10/AT10                | 75             | 4,5                | 85        | 15        | 76,5      | 2,5       |  |  |  |  | 2,46      |
| F (T20-75) 85x20   | SF7504URG                    | T20/AT20                | 75             | 8                  | 85        | 20        | 76,5      | 6         |  |  |  |  | 3,7       |
| F (5M-75) 85x15    | SF7505URG                    | HTD 5M                  | 75             | 3,8                | 85        | 15        | 76,5      | 2,5       |  |  |  |  | 4,93      |
| F (L300) 85x15     | SF7506URG                    | L                       | 76,2           | 3,6                | 85        | 15        | 78        | 2,5       |  |  |  |  | 4,95      |
| F (H300) 85x15     | SF7507URG                    | H                       | 76,2           | 4,3                | 85        | 15        | 78        | 2,5       |  |  |  |  | 5,1       |
| F (XH300) 85x20    | SF7508URG                    | XH                      | 76,2           | 11,2               | 85        | 20        | 78        | 8         |  |  |  |  | 5,12      |
| F (8M-85) 95x15    | SF8501URG                    | HTD 8M                  | 85             | 5,4                | 95        | 15        | 87        | 3,5       |  |  |  |  |           |
| F (14M-85) 95x20   | SF8502URG                    | HTD 14M                 | 85             | 10                 | 95        | 20        | 87        | 7         |  |  |  |  |           |
| F (T5-100) 110x10  | SF10001URG                   | T5                      | 100            | 2,2                | 110       | 10        | 102       | 1,6       |  |  |  |  |           |
| F (AT5-100) 110x10 | SF10002URG                   | AT5                     | 100            | 2,7                | 110       | 10        | 102       | 2         |  |  |  |  |           |
| F (T10-100) 110x15 | SF10003URG                   | T10/AT10                | 100            | 4,5                | 110       | 15        | 102       | 2,5       |  |  |  |  |           |
| F (T20-100) 110x20 | SF10004URG                   | T20/AT20                | 100            | 8                  | 110       | 20        | 102       | 6         |  |  |  |  |           |
| F (5M-100) 110x15  | SF10005URG                   | HTD 5M                  | 100            | 3,8                | 110       | 15        | 102       | 2,5       |  |  |  |  |           |
| F (8M-100) 110x15  | SF10006URG                   | HTD 8M                  | 100            | 5,4                | 110       | 15        | 102       | 3,5       |  |  |  |  |           |
| F (L400) 110x15    | SF10101URG                   | L                       | 101,6          | 3,6                | 110       | 15        | 103,6     | 2,5       |  |  |  |  |           |
| F (H400) 110x15    | SF10101URG                   | H                       | 101,6          | 4,3                | 110       | 15        | 103,6     | 2,5       |  |  |  |  |           |
| F (XH400) 110x20   | SF10103URG                   | XH                      | 101,6          | 11,2               | 110       | 20        | 103,6     | 8         |  |  |  |  |           |
| F (14M-115) 125x20 | SF11501URG                   | HTD 14M                 | 115            | 10                 | 125       | 20        | 117       | 7         |  |  |  |  |           |

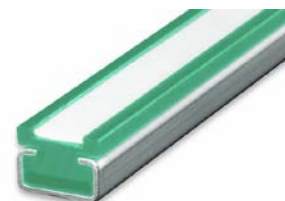
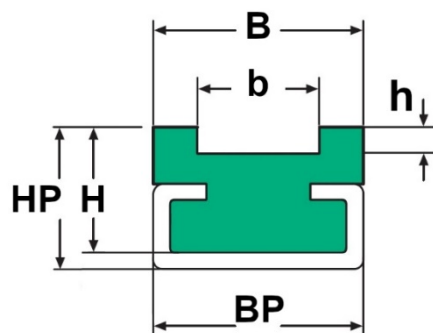

Standardní délka 2 METRY

(jiné délky na vyžádání)

Materiál: PE-UHMW vysokomolekulární polyetylen (PE-1000)

Barva: zelená

Specifická hmotnost: 0,945 g/cm<sup>3</sup>

Koeficient tření: 0,2 (P = 0,05 N/mm<sup>2</sup> – v = 0,6 m/s – t = 40°C)

Provozní teplota: -70°C +65°C

Lineární tepelná roztažnost: 2 mm každých 10°C, počínaje t = 20°C

Standard Length 2 METRES

(Other lengths on request)

Material: PE-UHMW High Molecular Weight Polyethylene (PE-1000)

Color: green

Specific weight: 0.945 g/cm<sup>3</sup>

Dynamic friction coefficient: 0.2 (P = 0.05N/mm<sup>2</sup> – v = 0.6 m/s – t = 40°C)

Operating temperature: -70°C +65°C

Linear thermal expansion: 2 mm every 10°C, starting from a temp. of 20°C

**Typ FC - pro ozubené řemeny / for timing belts**

| Typ               | Výrobní číslo | Typ řemenu | Šířka řem. | Tloušť řem.   | C-profil* | B    | H    | b    | h    | h1   | BP   | HP   | m    |
|-------------------|---------------|------------|------------|---------------|-----------|------|------|------|------|------|------|------|------|
| Type              | Product No.   | Belt Type  | Belt width | Belt thicken. | C-Profile | (mm) | (mm) | (mm) | (mm) | (mm) | (mm) | (mm) | (kg) |
| FC (L050) 20x15   | SFC31301URG   | L          | 12,7       | 3,6           | C-3       | 20   | 15   | 14,5 | 2,5  | 6    | 20   | 16   | 0,87 |
| FC (H050) 20x15   | SFC31302URG   | H          | 12,7       | 4,3           | C-3       | 20   | 15   | 14,5 | 2,5  | 6    | 20   | 16   | 1,13 |
| FC (5M-15) 28x15  | SFC51501URG   | HTD 5M     | 15         | 3,8           | C-5       | 28   | 15   | 16,5 | 2,5  | 6    | 28   | 18   | 1,78 |
| FC (8M-15) 28x15  | SFC51502URG   | HTD 8M     | 15         | 5,4           | C-5       | 28   | 15   | 16,5 | 3,5  | 8    | 28   | 20   | 2,77 |
| FC (T5-16) 28x15  | SFC51601URG   | T5         | 16         | 2,2           | C-5       | 28   | 15   | 17,5 | 1,6  | 6    | 28   | 18   | 1,17 |
| FC (AT5-16) 28x15 | SFC51602URG   | AT5        | 16         | 2,7           | C-5       | 28   | 15   | 17,5 | 2    | 6    | 28   | 18   | 1,51 |
| FC (T10-16) 28x15 | SFC51603URG   | T10/AT10   | 16         | 4,5           | C-5       | 28   | 15   | 17,5 | 2,5  | 6    | 28   | 18   | 2,21 |
| FC (L075) 28x15   | SFC51901URG   | L          | 19,05      | 3,6           | C-5       | 28   | 15   | 21   | 2,5  | 6    | 28   | 18   | 3,08 |
| FC (H075) 28x15   | SFC51902URG   | H          | 19,05      | 4,3           | C-5       | 28   | 15   | 21   | 2,5  | 6    | 28   | 18   | 4,62 |
| FC (8M-20) 28x15  | SFC52001URG   | HTD 8M     | 20         | 5,4           | C-5       | 28   | 15   | 21,5 | 3,5  | 8    | 28   | 20   | 6,17 |
| FC (T5-25) 35x15  | SFC52501URG   | T5         | 25         | 2,2           | C-5       | 35   | 15   | 26,5 | 1,6  | 6    | 28   | 18   | 1,51 |
| FC (AT5-25) 35x15 | SFC52502URG   | AT5        | 25         | 2,7           | C-5       | 35   | 15   | 26,5 | 2    | 6    | 28   | 18   | 2,21 |
| FC (T10-25) 35x15 | SFC52503URG   | T10/AT10   | 25         | 4,5           | C-5       | 35   | 15   | 26,5 | 2,5  | 6    | 28   | 18   | 3,08 |
| FC (T20-25) 35x20 | SFC52504URG   | T20/AT20   | 25         | 8             | C-5       | 35   | 20   | 26,5 | 6    | 11   | 28   | 23   | 4,62 |
| FC (5M-25) 35x15  | SFC52505URG   | HTD 5M     | 25         | 3,8           | C-5       | 35   | 15   | 26,5 | 2,5  | 6    | 28   | 18   | 6,16 |
| FC (8M-25) 35x20  | SFC52506URG   | HTD 8M     | 25         | 5,4           | C-5       | 35   | 20   | 26,5 | 3,5  | 8    | 28   | 20   | 6,2  |
| FC (L100) 35x15   | SFC52507URG   | L          | 25,4       | 3,6           | C-5       | 35   | 15   | 27   | 2,5  | 7    | 28   | 19   | 6,21 |
| FC (H100) 35x15   | SFC52508URG   | H          | 25,4       | 4,3           | C-5       | 35   | 15   | 27   | 2,5  | 7    | 28   | 19   | 6,22 |
| FC (XH100) 35x20  | SFC52509URG   | XH         | 25,4       | 11,2          | C-5       | 35   | 20   | 27   | 8    | 13   | 28   | 25   | 6,23 |
| FC (8M-30) 40x20  | SFC93001URG   | HTD 8M     | 30         | 5,4           | C-9       | 40   | 20   | 31,5 | 3,5  | 8    | 28   | 26   | 6,3  |
| FC (T5-32) 40x15  | SFC93201URG   | T5         | 32         | 2,2           | C-9       | 40   | 15   | 33,5 | 1,6  | 6    | 38   | 24   | 6,3  |
| FC (AT5-32) 40x15 | SFC93202URG   | AT5        | 32         | 2,7           | C-9       | 40   | 15   | 33,5 | 2    | 6    | 38   | 24   | 6,32 |
| FC (T10-32) 40x15 | SFC93203URG   | T10/AT10   | 32         | 4,5           | C-9       | 40   | 15   | 33,5 | 2,5  | 6    | 38   | 24   | 6,5  |
| FC (T20-32) 40x20 | SFC93204URG   | T20/AT20   | 32         | 8             | C-9       | 40   | 20   | 33,5 | 6    | 11   | 38   | 29   | 6,52 |
| FC (5M-32) 40x15  | SFC93205URG   | HTD 5M     | 32         | 3,8           | C-9       | 40   | 15   | 33,5 | 2,5  | 6    | 38   | 24   | 6,54 |

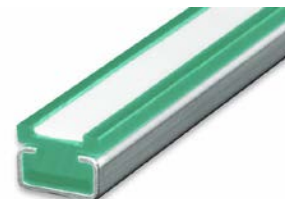
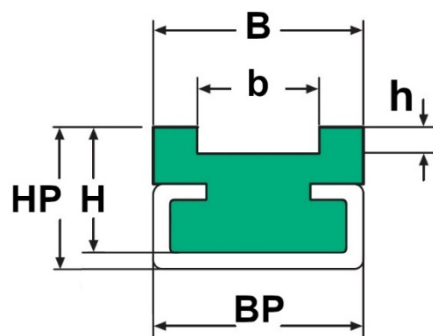

Standardní délka 2 METRY

(jiné délky na vyžádání)

Materiál: PE-UHMW vysokomolekulární polyetylen (PE-1000)

Barva: zelená

Specifická hmotnost: 0,945 g/cm<sup>3</sup>

Koeficient tření: 0,2 (P = 0,05 N/mm<sup>2</sup> – v = 0,6 m/s – t = 40°C)

Provozní teplota: -70°C +65°C

Lineární tepelná roztažnost: 2 mm každých 10°C, počínaje t = 20°C

Standard Length 2 METRES

(Other lengths on request)

Material: PE-UHMW High Molecular Weight Polyethylene (PE-1000)

Color: green

Specific weight: 0.945 g/cm<sup>3</sup>

Dynamic friction coefficient: 0.2 (P = 0.05N/mm<sup>2</sup> – v = 0.6 m/s – t = 40°C)

Operating temperature: -70°C +65°C

Linear thermal expansion: 2 mm every 10°C, starting from a temp. of 20°C

**Typ FC - pro ozubené řemeny / for timing belts**

| Typ               | Výrobní číslo | Typ řemenu | Šířka řem. | Tloušť. řem. | C-profil*  | B    | H    | b    | h    | h1   | BP   | HP   | m    |
|-------------------|---------------|------------|------------|--------------|------------|------|------|------|------|------|------|------|------|
| Type              | Product No.   | Belt Type  | Belt width | Belt thickn. | C-Profile* | (mm) | (mm) | (mm) | (mm) | (mm) | (mm) | (mm) | (kg) |
| FC (8M-32) 40x20  | SFC93206URG   | HTD 8M     | 32         | 5,4          | C-9        | 40   | 20   | 33,5 | 3,5  | 11   | 38   | 29   | 6,55 |
| FC (14M-32) 40x20 | SFC93207URG   | HTD 14M    | 32         | 10           | C-9        | 40   | 20   | 33,5 | 7    | 13   | 38   | 31   | 6,56 |
| FC (L150) 50x15   | SFC93801URG   | L          | 38,1       | 3,6          | C-9        | 50   | 15   | 40   | 2,5  | 6    | 38   | 24   | 6,56 |
| FC (H150) 50x15   | SFC93802URG   | H          | 38,1       | 4,3          | C-9        | 50   | 15   | 40   | 2,5  | 6    | 38   | 24   | 6,57 |
| FC (XH150) 50x20  | SFC93803URG   | XH         | 38,1       | 11,2         | C-9        | 50   | 20   | 40   | 8    | 13   | 38   | 31   | 6,58 |
| FC (T5-50) 60x15  | SFC95001URG   | T5         | 50         | 2,2          | C-9        | 60   | 15   | 51,5 | 1,6  | 6    | 38   | 24   | 6,59 |
| FC (AT5-50) 60x15 | SFC95002URG   | AT5        | 50         | 2,7          | C-9        | 60   | 15   | 51,5 | 2    | 6    | 38   | 24   | 6,6  |
| FC (T10-50) 60x15 | SFC95003URG   | T10/AT10   | 50         | 4,5          | C-9        | 60   | 15   | 51,5 | 2,5  | 6    | 38   | 24   | 6,61 |
| FC (T20-50) 60x20 | SFC95004URG   | T20/AT20   | 50         | 8            | C-9        | 60   | 20   | 51,5 | 6    | 11   | 38   | 29   | 6,62 |
| FC (5M-50) 60x15  | SFC95005URG   | HTD 5M     | 50         | 3,8          | C-9        | 60   | 15   | 51,5 | 2,5  | 6    | 38   | 24   | 6,63 |
| FC (8M-50) 60x20  | SFC95006URG   | HTD 8M     | 50         | 5,4          | C-9        | 60   | 20   | 51,5 | 3,5  | 11   | 38   | 29   | 6,64 |
| FC (14M-50) 60x20 | SFC95007URG   | HTD 14M    | 50         | 10           | C-9        | 60   | 20   | 51,5 | 7    | 13   | 38   | 31   | 6,65 |
| FC (L200) 60x15   | SFC95101URG   | L          | 50,8       | 3,6          | C-9        | 60   | 15   | 53   | 2,5  | 6    | 38   | 24   | 6,66 |
| FC (H200) 60x15   | SFC95102URG   | H          | 50,8       | 4,3          | C-9        | 60   | 15   | 53   | 2,5  | 6    | 38   | 24   | 6,67 |
| FC (XH200) 60x20  | SFC95103URG   | XH         | 50,8       | 11,2         | C-9        | 60   | 20   | 53   | 8    | 13   | 38   | 31   | 6,68 |

\* Upozornění: C - profily nejsou součástí. C-profil příslušné velikosti je nutno objednávat jako samostatnou položku. /

Note: C - profiles are not included. The C-profile of the appropriate size must be ordered as a separate item.



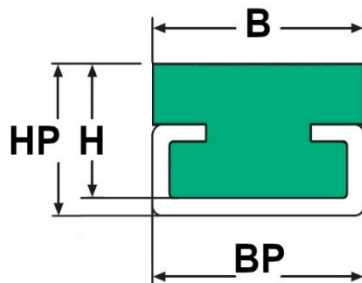

Standardní délka 2 METRY

(jiné délky na vyžádání)

Materiál: PE-UHMW vysokomolekulární polyetylen (PE-1000)

Barva: zelená

Specifická hmotnost: 0,945 g/cm<sup>3</sup>

Koeficient tření: 0,2 (P = 0,05 N/mm<sup>2</sup> – v = 0,6 m/s – t = 40°C)

Provozní teplota: -70°C +65°C

Lineární tepelná roztažnost: 2 mm každých 10°C, počínaje t = 20°C

Standard Length 2 METRES

(Other lengths on request)

Material: PE-UHMW High Molecular Weight Polyethylene (PE-1000)

Color: green

Specific weight: 0.945 g/cm<sup>3</sup>

Dynamic friction coefficient: 0.2 (P = 0.05N/mm<sup>2</sup> – v = 0.6 m/s – t = 40°C)

Operating temperature: -70°C +65°C

Linear thermal expansion: 2 mm every 10°C, starting from a temp. of 20°C

**Typ PC - pro ploché / for flat belts**

| Typ<br>Type | Výrobní číslo<br>Product No. | C-profil *<br>C-Profile * | B<br>(mm) | H<br>(mm) | h<br>(mm) | BP<br>(mm) | HP<br>(mm) |  |  |  |  |  | m<br>(kg) |
|-------------|------------------------------|---------------------------|-----------|-----------|-----------|------------|------------|--|--|--|--|--|-----------|
| PC 20x10    | SPC1C310URG                  | C-3                       | 20        | 10        | 4         | 20         | 14         |  |  |  |  |  | 0,35      |
| PC 20x15    | SPC2C315URG                  | C-3                       | 20        | 15        | 7         | 20         | 17         |  |  |  |  |  | 0,49      |
| PC 20x20    | SPC3C320URG                  | C-3                       | 20        | 20        | 12        | 20         | 22         |  |  |  |  |  | 0,72      |
| PC 28x10    | SPC4C510URG                  | C-3                       | 28        | 10        | 3         | 28         | 15         |  |  |  |  |  | 0,52      |
| PC 28x15    | SPC5C515URG                  | C-5                       | 28        | 15        | 6         | 28         | 18         |  |  |  |  |  | 0,79      |
| PC 28x15    | SPC51C515URG                 | C-5                       | 28        | 15        | 9,5       | 28         | 22         |  |  |  |  |  |           |
| PC 28x20    | SPC6C520URG                  | C-5                       | 28        | 20        | 12        | 28         | 24         |  |  |  |  |  |           |
| PC 38x10    | SPC7C910URG                  | C-9                       | 38        | 10        | 3         | 38         | 21         |  |  |  |  |  | 0,68      |
| PC 38x15    | SPC8C915URG                  | C-9                       | 38        | 15        | 6         | 38         | 24         |  |  |  |  |  | 1,03      |
| PC 38x15    | SPC81C915URG                 | C-9                       | 38        | 15        | 9         | 38         | 27         |  |  |  |  |  |           |
| PC 38x20    | SPC9C920URG                  | C-9                       | 38        | 20        | 12        | 38         | 30         |  |  |  |  |  |           |

\* Upozornění: C - profily nejsou součástí. C-profil příslušné velikosti je nutno objednávat jako samostatnou položku. /

Note: C - profiles are not included. The C-profile of the appropriate size must be ordered as a separate item.

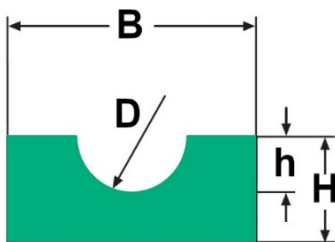

Standardní délka 2 METRY

(jiné délky na vyžádání)

Materiál: PE-UHMW vysokomolekulární polyetylen (PE-1000)

Barva: zelená

Specifická hmotnost: 0,945 g/cm<sup>3</sup>

Koeficient tření: 0,2 (P = 0,05 N/mm<sup>2</sup> – v = 0,6 m/s – t = 40°C)

Provozní teplota: -70°C +65°C

Lineární tepelná roztažnost: 2 mm každých 10°C, počínaje t = 20°C

Standard Length 2 METRES

(Other lengths on request)

Material: PE-UHMW High Molecular Weight Polyethylene (PE-1000)

Color: green

Specific weight: 0.945 g/cm<sup>3</sup>

Dynamic friction coefficient: 0.2 (P = 0.05N/mm<sup>2</sup> – v = 0.6 m/s – t = 40°C)

Operating temperature: -70°C +65°C

Linear thermal expansion: 2 mm every 10°C, starting from a temp. of 20°C

**Typ R - pro kruhové řemeny / for round belts DIN 8187**

| Typ<br>Type | Výrobní číslo<br>Product No. | Typ - Průměr řemenu<br>Type - Belt diameter | B<br>(mm) | H<br>(mm) | h<br>(mm) | d<br>(mm) |  |  |  |  |  | m<br>(kg) |
|-------------|------------------------------|---|-----------|-----------|-----------|-----------|--|--|--|--|--|-----------|
| RC4 15x10   | SR04URG                      | 4 mm  | 15        | 10        | 2         | 4         |  |  |  |  |  | 0,36      |
| RC5 15x10   | SR05URG                      | 5 mm  | 15        | 10        | 2,5       | 5         |  |  |  |  |  | 0,36      |
| RC6 20x10   | SR06URG                      | 6 mm  | 20        | 10        | 3         | 6         |  |  |  |  |  | 0,36      |
| RC7 20x10   | SR07URG                      | 7 mm  | 20        | 10        | 3,5       | 7         |  |  |  |  |  | 0,35      |
| RC8 20x10   | SR08URG                      | 8 mm  | 20        | 10        | 4         | 8         |  |  |  |  |  | 0,35      |
| RC10 25x12  | SR10URG                      | 10 mm                                       | 25        | 12        | 5         | 10        |  |  |  |  |  | 0,35      |
| RC12 25x12  | SR12URG                      | 12 mm                                       | 25        | 12        | 6         | 12        |  |  |  |  |  | 0,34      |
| RC15 25x15  | SR15URG                      | 15 mm                                       | 25        | 15        | 7,5       | 15        |  |  |  |  |  | 0,34      |
| RC18 30x20  | SR18URG                      | 18 mm                                       | 30        | 20        | 9         | 18        |  |  |  |  |  | 0,32      |
| RC20 30x20  | SR20URG                      | 20 mm                                       | 30        | 20        | 10        | 20        |  |  |  |  |  | 0,32      |

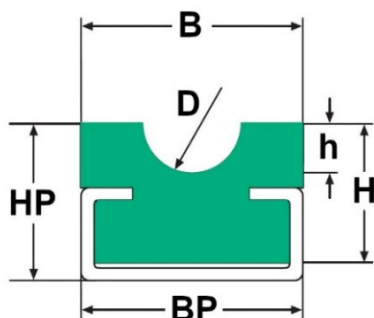

**Standardní délka 2 METRY**

(jiné délky na vyžádání)

Materiál: PE-UHMW vysokomolekulární polyetylen (PE-1000)

Barva: zelená

Specifická hmotnost: 0,945 g/cm<sup>3</sup>

Koeficient tření: 0,2 (P = 0,05 N/mm<sup>2</sup> – v = 0,6 m/s – t = 40°C)

Provozní teplota: -70°C +65°C

Lineární tepelná roztažnost: 2 mm každých 10°C, počínaje t = 20°C

**Standard Length 2 METRES**

(Other lengths on request)

Material: PE-UHMW High Molecular Weight Polyethylene (PE-1000)

Color: green

Specific weight: 0.945 g/cm<sup>3</sup>

Dynamic friction coefficient: 0.2 (P = 0.05N/mm<sup>2</sup> – v = 0.6 m/s – t = 40°C)

Operating temperature: -70°C +65°C

Linear thermal expansion: 2 mm every 10°C, starting from a temp. of 20°C

**Typ RC - pro kruhové řemeny / for round belts**

| Typ<br>Type | Výrobní číslo<br>Product No. | Typ - Průměr řemenu<br>Type - Belt diameter | C-profil *<br>C-Profile * | B<br>(mm) | H<br>(mm) | h<br>(mm) | d<br>(mm) | BP<br>(mm) | HP<br>(mm) | m<br>(kg) |
|-------------|------------------------------|---|---------------------------|-----------|-----------|-----------|-----------|------------|------------|-----------|
| RC4 20x10   | SR04C3URG                    | 4 mm  | C-3                       | 20        | 10        | 2         | 4         | 20         | 14         | 0,36      |
| RC5 20x10   | SR05C3URG                    | 5 mm  | C-3                       | 20        | 10        | 2,5       | 5         | 20         | 14         | 0,36      |
| RC6 20x10   | SR06C3URG                    | 6 mm  | C-3                       | 20        | 10        | 3         | 6         | 20         | 14         | 0,36      |
| RC7 20x10   | SR07C3URG                    | 7 mm  | C-3                       | 20        | 10        | 3,5       | 7         | 20         | 14         | 0,35      |
| RC8 20x10   | SR08C3URG                    | 8 mm  | C-3                       | 20        | 10        | 4         | 8         | 20         | 14         | 0,35      |
| RC10 25x15  | SR10C5URG                    | 10 mm                                       | C-5                       | 25        | 15        | 5         | 10        | 28         | 18         | 0,35      |
| RC12 25x15  | SR12C5URG                    | 12 mm                                       | C-5                       | 25        | 15        | 6         | 12        | 28         | 18         | 0,34      |
| RC15 25x15  | SR15C5URG                    | 15 mm                                       | C-5                       | 25        | 15        | 7,5       | 15        | 28         | 20         | 0,34      |
| RC18 28x20  | SR18C5URG                    | 18 mm                                       | C-5                       | 28        | 20        | 9         | 18        | 28         | 24         | 0,32      |
| RC20 28x20  | SR20C5URG                    | 20 mm                                       | C-5                       | 28        | 20        | 10        | 20        | 28         | 24         | 0,32      |

\* **Upozornění: C - profily nejsou součástí. C-profil příslušné velikosti je nutno objednávat jako samostatnou položku. /**

Note: C - profiles are not included. The C-profile of the appropriate size must be ordered as a separate item.

### C3 - C5 - C9 - C10 - C11

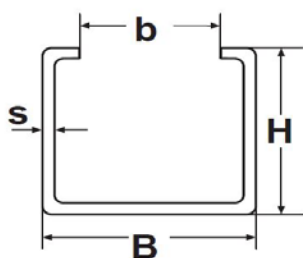

### C-14

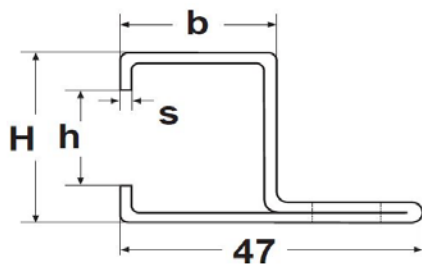

### C-15

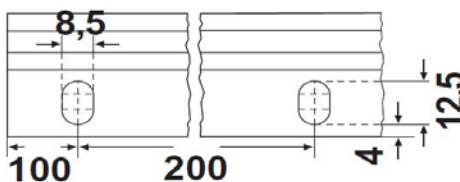
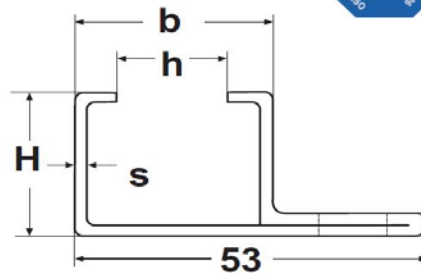

Standardní vrtání pro C-14 a C-15 / Standard drilling for C-14 and C-15

Standardní délka 2 METRY

(jiné délky na vyžádání)

Materiál: ST - ocel galvanicky pozinkovaná, SS - nerezavějící ocel

Standard Length 2 METRES

(Other lengths on request)

Material: ST - galvanized steel, SS - stainless steel INOX AISI 304

## Kovové C-profilý pro vedení řetězů a řemenů / Metal C-Profiles for Chain and Belt Guides

| Typ<br>Type | Výrobní číslo<br>Product No. | Materiál<br>Material | B<br>(mm) | H<br>(mm) | b<br>(mm) | h<br>(mm) | S<br>(mm) | m<br>(kg/m) |
|-------------|------------------------------|----------------------|-----------|-----------|-----------|-----------|-----------|-------------|
| C3          | SC03                         | ST                   | 20        | 10        | 10        | -         | 1,5       | 0,49        |
| C5          | SC05                         | ST                   | 28        | 12        | 14        | -         | 1,5       | 0,65        |
| C9          | SC09                         | ST                   | 38        | 18        | 22        | -         | 1,5       | 0,98        |
| C10         | SC10                         | ST                   | 30        | 24        | 20        | -         | 1,5       | 0,94        |
| C11         | SC11                         | ST                   | 45        | 40        | 31        | -         | 1,5       | 2,05        |
| C3X         | SC03X                        | SS                   | 20        | 10        | 10        | -         | 1,5       | 0,49        |
| C5X         | SC05X                        | SS                   | 28        | 12        | 14        | -         | 1,5       | 0,65        |
| C9X         | SC09X                        | SS                   | 38        | 18        | 22        | -         | 1,5       | 0,98        |
| C10X        | SC10X                        | SS                   | 30        | 24        | 20        | -         | 1,5       | 0,94        |
| C11X        | SC11X                        | SS                   | 45        | 40        | 31        | -         | 1,5       | 2,05        |
| C14         | SC14                         | ST                   | -         | 31        | 25        | 20        | 2         | 1,20        |
| C15         | SC15                         | ST                   | -         | 25        | 31        | 20        | 2         | 1,20        |
| C14X        | SC14X                        | SS                   | -         | 31        | 25        | 20        | 2         | 1,20        |
| C15X        | SC15X                        | SS                   | -         | 25        | 31        | 20        | 2         | 1,20        |

**Upozornění: U vedení pro C - profily nejsou C - profily součástí dodávky. C - profily je nutno objednávat jako samostatnou položku. /**

Note: C - profiles are not included. The C-profile of the appropriate size must be ordered as a separate item.

