

SITEX® FL

Description

The SITEX® FL couplings are designed for optimizing the connections between Diesel engines and hydraulic pumps (hydrostatic transmissions). SITEX FL couplings consist of a steel hub and fiberglass reinforced polyamide flange which offers both mechanical strength and dimensional stability in a variety of

temperature ranges.

The special teeth allow SITEX® FL couplings to compensate for small misalignments thus avoiding wear.

The steel-Polyamide coupling allows maintenance free continuous operation.

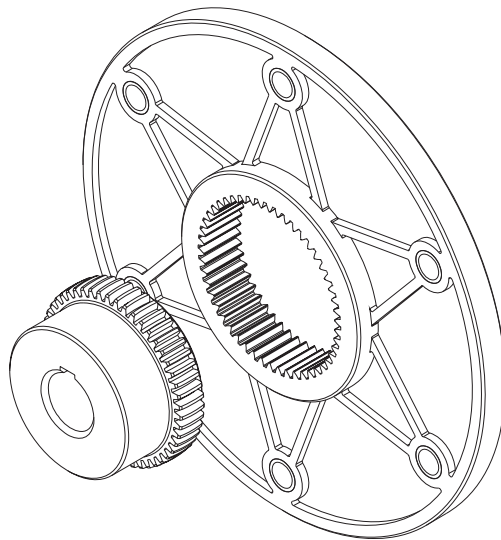

2. Main characteristics and advantages

Minimum dimensions: The entire coupling is usually installed inside an engine housing, minimizing the axial dimensions thus reducing the tools required for installation.

Axial misalignments: The hub teething can move freely axially inside the Polyamide flange avoiding axial forces which may arise on the pump shaft.

Heat stability: The special fiberglass reinforced Polyamide flange is designed to operate in internal combustion engine environments without air cooling and up to 140° C.

Maintenance free: The SITEX® FL joints are maintenance and lubrication free.

Quick assembling: Blind assembly makes installation of the SITEX FL quick and easy.

Angular misalignments: The special teeth allow angular misalignment correction, protecting the bearings against angular forces.

Stiffness: The stiffness of the SITEX FL coupling allow for torsionally vibration-free operation.

The SITEX® FL couplings are used in connections between the flywheels of the internal combustion engines and: hydro-pumps, rotating pistons, and compressor blades.

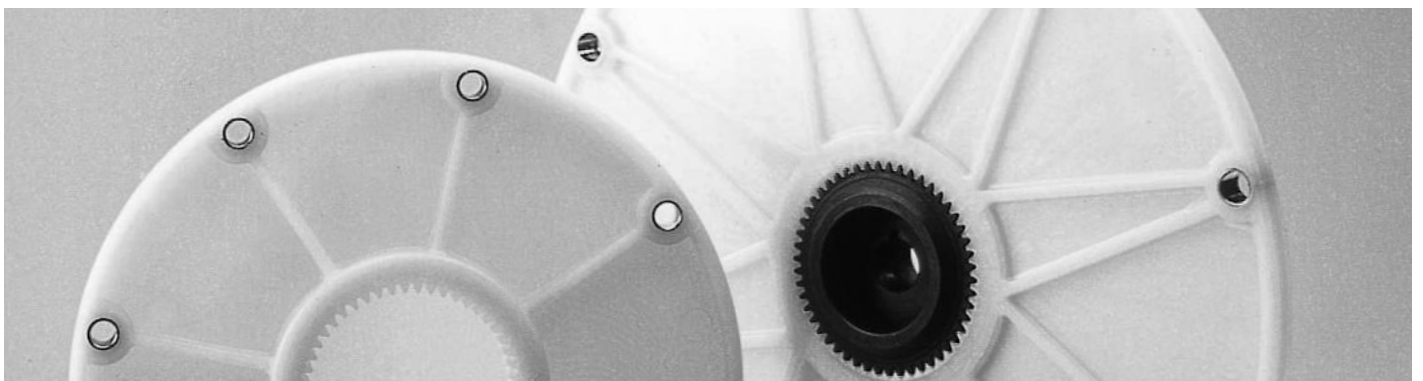

Flange dimensions in accordance with SAE J620

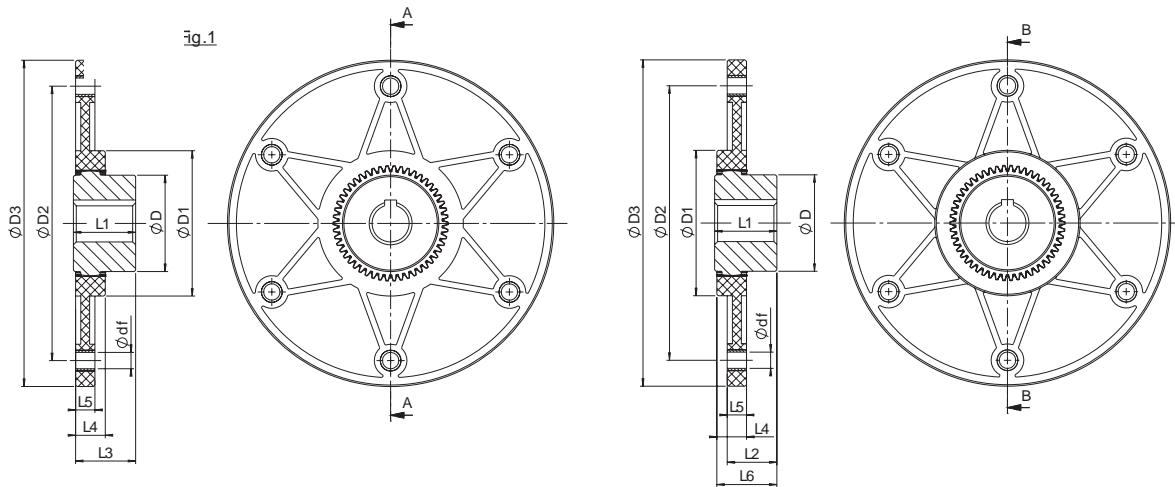

SAE flange size	Dimensions [mm]											
	Max. bore	D	D1	D2	D3	df x z	L1	L2	L3	L4	L5	L6
GDF 42 FL 6 1/2"	42	65	100	200,02	215,9	9 x 6	42	33	42	20	13	40
GDF 42 FL 7 1/2"	42	65	100	222,25	241,3	9 x 8	42	33	42	20	13	40
GDF 42 FL 8"	42	65	100	244,47	263,52	11 x 6	42	33	42	20	13	40
GDF 42 FL 10"	42	65	100	295,27	314,32	11 x 8	42	33	42	20	13	40
GDF 48 FL 6 1/2"	48	68	100	200,02	215,9	9 x 6	50	41	50	20	13	48
GDF 48 FL 7 1/2"	48	68	100	222,25	241,3	9 x 8	50	41	50	20	13	48
GDF 48 FL 8"	48	68	100	244,47	263,52	11 x 6	50	41	50	20	13	48
GDF 48 FL 10"	48	68	100	295,27	314,32	11 x 8	50	41	50	20	13	48
GDF 48P FL 6 1/2"	48	68	100	200,02	215,9	9 x 6	50	38	45	20	13	46
GDF 48P FL 7 1/2"	48	68	100	222,25	241,3	9 x 8	50	38	45	20	13	46
GDF 48P FL 8"	48	68	100	244,47	263,52	11 x 6	50	38	45	20	13	46
GDF 48P FL 10"	48	68	100	295,27	314,32	11 x 8	50	38	45	20	13	46
GDF 65 FL 8"	65	96	132	244,47	263,52	11 x 6	70	60	69	27	21	66
GDF 65 FL 10"	65	96	132	295,27	314,32	11 x 8	70	60	69	27	21	66
GDF 65 FL 11 1/2"	65	96	132	333,37	352,42	11 x 8	70	60	69	27	21	66
GDF 65P FL 8"	65	96	132	244,47	263,52	11 x 6	70	60	69	27	21	66
GDF 65P FL 10"	65	96	132	295,27	314,32	11 x 8	70	60	69	27	21	66
GDF 65P FL 11 1/2"	65	96	132	333,37	352,42	11 x 8	70	60	69	27	21	66
GDF 80 FL 11 1/2"	80	124	170	333,37	352,42	11 x 8	90	78	87	30	21	87

48P and 65P are for hubs with over-sized toothed band.

Order form

Hub **GDM 12/48 F32**

GDM: SITEX® hub

Size

L: long hub execution
F...: bore diameter

Flange **GDF 65 FL11-1/2**

GDF: SITEX® FL Flange

Bore

SAE flange size

SITEX FL

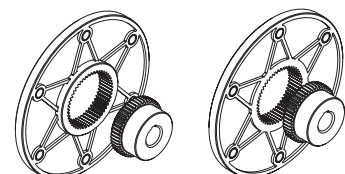

Special flange dimensions

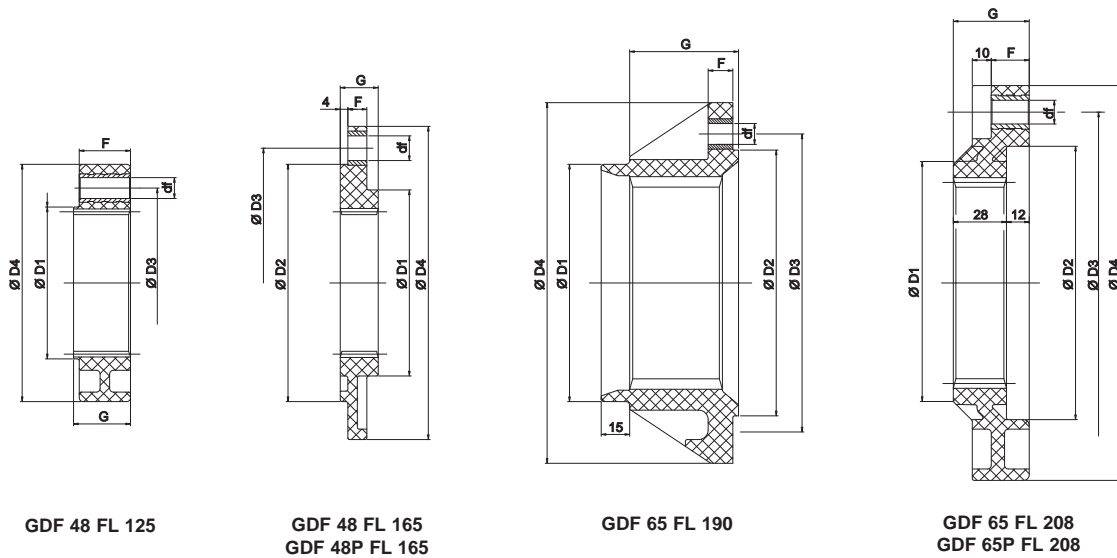

Special flange size	Max. bore	D1 [mm]	D2 [mm]	D3 [mm]	D4 [mm]	F [mm]	G [mm]	df x z
GDF 48 FL 125	48	80	-	100	125	27	30	11 x 3
GDF 48 FL 165	48	98	125	142	165	10	20	13 x 6
GDF 48P FL 165	48	98	125	142	165	10	20	13 x 6
GDF 65 FL 190	65	125	140	160	190	13	57	11 x 6
GDF 65 FL 208	65	125	144	180	208	20	40	18 x 8
GDF 65P FL 208	65	125	144	180	208	20	40	18 x 8

Flywheel bellhousing

The dimensions of the flywheel Bell housing plates are in accordance with SAE 617.

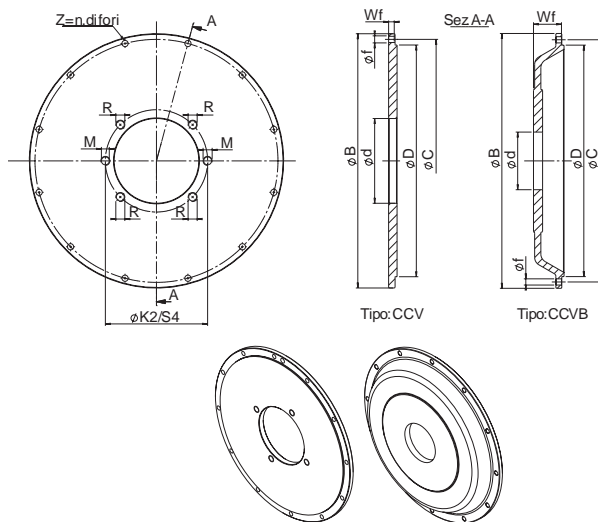

SAE - Flywheel Bellhousing							
SAE type	D [mm]	B [mm]	C [mm]	Number of holes Z	f [mm]	CCV	CCVB
						Wf	
SAE 6	266,7	308	285,8	8	11	10,5	-
SAE 5	314,32	356	333,4	8	11	10,5	25
SAE 4	361,95	403	381	12	11	10,5	35
							50
SAE 3	409,58	451	428,6	12	11	10,5	50
SAE 2	447,68	489	466,7	12	11	14	-

Order form

Flywheel bell housing	CCV	6	B/4
Flywheel bellhousing	CCV	6	B/4
"B" type	B		
SAE type for engine flange			
SAE type of pump flange and number of pump fixing holes			

Pump assembling SAE dimensions							
SAE Pump	Center bore d [mm]	Pump fixing holes					
		n. 2 holes			n. 4 holes		
		K2	M	S4	R		
AA	50,8	82,6	M8	5/16"	-	-	-
A	82,55	106,4	M10	3/8"	104,6	M10	3/8"
B	101,6	146	M12	1/2"	127	M12	1/2"
C	127	181	M16	5/8"	162	M12	1/2"
D	152,4	228,6	M16	5/8"	228,6	M16	5/8"

Technical characteristics

Size	Misalignment			Torque			Weight / Moment of inertia						Dynamic torsional rigidity +60°C dampening factor [Ψ] = 0,4 [Nm/rad]				
	Axial [mm]	Angular [°]	Radial [mm]	Nominal T _{KN} [Nm]	Max T _{Kmax} [Nm]	Reversible T _{KW} [Nm]	Hub		SAE SITEX® FL flange								
									6-1/2"	7-1/2"	8"	10"	11-1/2"	0,25 T _{KN}	0,50 T _{KN}	0,75 T _{KN}	1,00 T _{KN}
8/42	2	1°	0,2	240	600	120	Kg	0,68	0,39	0,455	0,565	0,8	-	33 x 10 ³	78 x 10 ³	110 x 10 ³	130 x 10 ³
							Kgm ²	0,0006	0,003	0,004	0,006	0,011	-				
12/48	2	1°	0,2	250	620	125	Kg	0,75	0,4	0,52	0,5	0,75	-	33 x 10 ³	78 x 10 ³	110 x 10 ³	130 x 10 ³
							Kgm ²	0,0007	0,003	0,004	0,006	0,011	-				
12/48 P	1	1°	0,2	310	780	155	Kg	0,85	0,4	0,52	0,5	0,75	-	38 x 10 ³	88 x 10 ³	125 x 10 ³	148 x 10 ³
							Kgm ²	0,0007	0,003	0,004	0,006	0,011	-				
30/60	2	1°	0,3	660	1650	330	Kg	2,4	-	-	0,8	0,93	1,08	58 x 10 ³	142 x 10 ³	205 x 10 ³	250 x 10 ³
							Kgm ²	0,005	-	-	0,009	0,015	0,023				
30/60 P	1	1°	0,2	800	1950	400	Kg	2,45	-	-	0,8	0,93	1,08	76 x 10 ³	185 x 10 ³	270 x 10 ³	330 x 10 ³
							Kgm ²	0,005	-	-	0,009	0,015	0,023				
40/80	2	1°	0,3	1300	3100	650	Kg	5,1	-	-	-	-	1,13	190 x 10 ³	420 x 10 ³	590 x 10 ³	710 x 10 ³
							Kgm ²	0,015	-	-	-	-	0,023				

SITEX® FL

Selection

For a proper sizing a safety factor $k = 1,3 - 1,6$ must be considered in accordance to the application. Or, the coupling nominal torque must be greater than or equal to the engine torque multiplied by k :

$$T_{KN} \geq T_N \cdot k$$

T_{KN} = coupling nominal torque

T_N = engine side torque

k = safety factor selected in accordance with the use

Applications

k factor

Tandem rollers.....	1,6
Asphalt processing machines.....	1,4
Agricultural machines.....	1,4
Fork lift trucks.....	1,6
Concrete Mixer.....	1,3
Self-propelled cranes.....	1,4
Excavators	1,4
Farm tractors.....	1,4
Road working machines.....	1,4

Assembling

The versatility of the SITEX FL couplings allows for numerous assembly options with different hub lengths giving consumers the ability to obtain the suitable dimension for every application.

1) Center the flange on the fly-wheel in correspondence to the seat and tighten the fixing screws DIN 912 – 8.8 class in accordance with the torque values shown in the table:

Screw	Ms
M 8	25 Nm
M 10	86 Nm
M 12	355 Nm

2) Center the fly-wheel cover plate in relation to the seat on the engine bellhousing. Tighten the screws.

3) Install the toothed hub onto the pump shaft. For split clamp hub, tighten in accordance with the torques shown in the table.

Coupling	Screw	Ms
8/42 - 12/48	M 10	49 Nm
30/60	M 12	86 Nm
40/80	M 16	355 Nm

4) Move the pump-hub assembly through the fly-wheel cover plate and up to the stop. Tighten the screws.

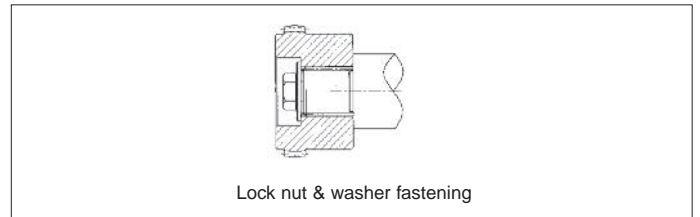
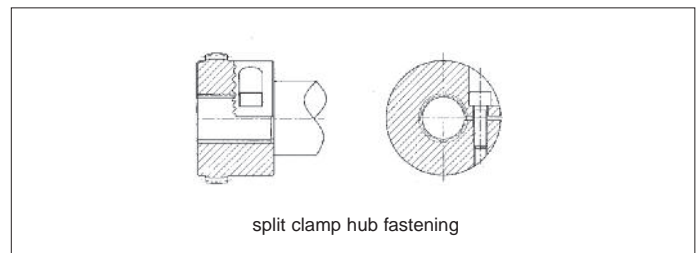
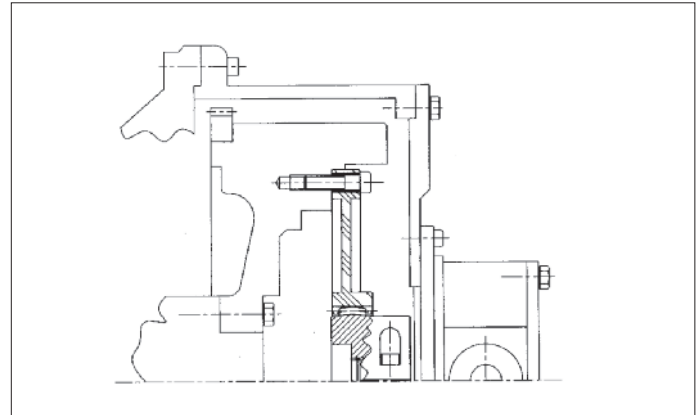

FLD execution

The SITEX® FLD couplings are designed for applications which combine with diesel engines pulley. These couplings allow for belt replacement without pump disassembly. The operating temperature range is from -25°C to 100°C

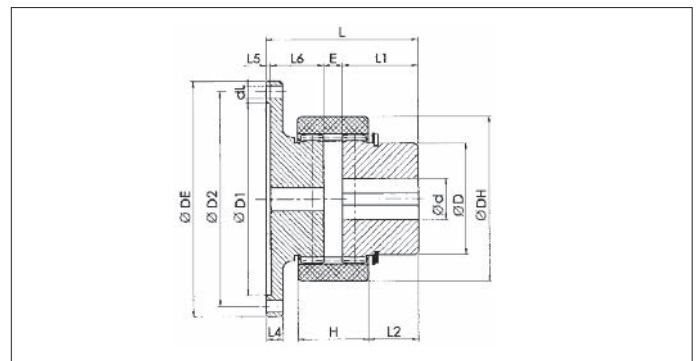

Size	T _{KN} [Nm]	T _{Kmax} [Nm]	T _{KW} [Nm]	d _{max} [mm]	L5 [mm]	L1 [mm]	L4 [mm]	L6 [mm]	E [mm]	L [mm]	H [mm]	L2 [mm]	D [mm]	DH [mm]
35 / 28 FLD	45	90	23	26	4	35,5	10	28,5	13	81	39	22,5	42	70
5 / 32 FLD	60	120	30	30	4	35,5	12	28,5	13	81	40	21,5	48	84
8 / 42 FLD	140	280	70	42	5	37,5	13	30,5	13	86	43	22,5	63	100
30 / 60 FLD	380	780	190	65	5	64	16	44	16	129	60	42	95	140
40 / 80 FLD	700	1400	350	80	6	83	20	53	20	162	69	58,5	120	175

T_{KN} = Nominal Coupling torque T_{Kmax} = Max Coupling torque T_{KW} = Max reversal torque

Splined bore hub

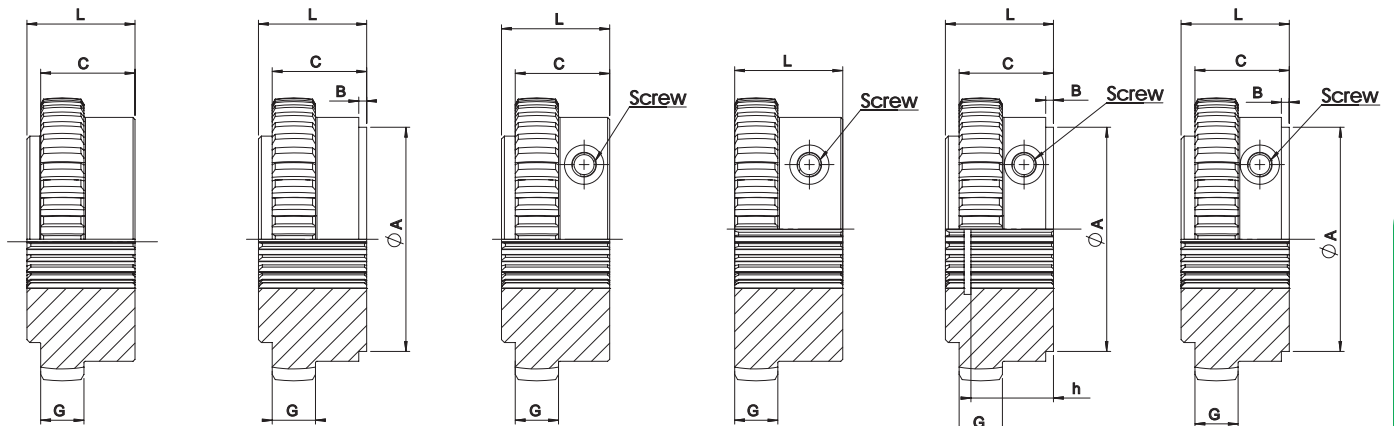

Fig.1 Splined bore hub Fig.2 Splined bore hub Fig.3 Clamping hub with splined bore Fig.4 Clamping hub with splined bore Fig.5 Clamping hub with splined bore and seeger-ring seating Fig.6 Clamping hub with splined bore

Hub	Splines DIN 5480									
	Fig.	Splines type	A [mm]	B [mm]	C [mm]	G [mm]	h [mm]	L [mm]	Screw	Ms [Nm]
42	1	25 x 1.25 x 18	-	-	37	13	-	42	-	-
	3	25 x 1.25 x 18	-	-	37	13	-	42	M10	49
	6	30 x 2 x 14	60	6	37	13	-	42	M10	49
48	2	30 x 2 x 14	60	6	45	13	-	50	-	-
	6	30 x 2 x 14	60	6	45	13	-	50	M10	49
65	2	35 x 2 x 16	60	6	49	20	-	55	-	-
	6	35 x 2 x 16	60	6	54	20	-	60	M12	86
	2	40 x 2 x 18	78	6	49	20	-	55	-	-
	6	40 x 2 x 18	78	6	54	20	-	60	M12	86
	6	45 x 2 x 21	78	6	49	20	-	55	M12	86
80	3	50 x 2 x 24	-	-	49	25	-	55	M16	295

Hub	Splines SAE J498											
	Fig.	Splines type	Tooth	DP	A [mm]	B [mm]	C [mm]	h [mm]	G [mm]	L [mm]	Screw	Ms [Nm]
42	3	PH-S 5/8"	9	16/32	-	-	37	-	13	42	M10	49
	4	PI-S 3/4"	11	16/32	-	-	-	-	13	42	M10	49
	6	PB-S 7/8"	13	16/32	60	3	37	-	13	42	M10	49
	5	PB-BS 1"	15	16/32	50	6	37	27	13	42	M10	49
48	5	PA-S 1 3/8"	21	16/32	52	7	45	45	13	50	M10	49
65	5	PA-S 1 3/8"	21	16/32	52	5	49	48	20	55	M12	86
	5	PC-S 1 1/4"	14	12/24	52	5	49	44	20	55	M12	86
80	3	PE 1 3/4"	27	16/32	-	-	49	-	25	55	M16	295

Ms= clamp screws tightening torque
Other splined bores and executions are available upon request.

SITEX® FL coupling selection

Motor side

Engine nominal power [kW]

Number of rotations at nominal power [rpm]

SAE dimension of the engine housing

Engine max torque [Nm]

Number of rotations [rpm]

Engine flywheel dimension

Driven side

Type of the pump shaft (specify splined type, diameter and length)

Type of the pump flange
