



Birn's flexible couplings are suitable for the most common machine constructions requiring a power transmission with dampend vibration. Instantaneous shock-loads originating from an irregular cycle of operation of engines as well as working machines, are eliminated or effectively dampend. The couplings ensure a reliable power transmission, also with the often inevitable axial, radial, and angular misalignment between the coupled machines.

In built features couplings ensures safe continuous operation at unforeseen overloads by means of the tested principle for claw- and bolt-couplings. Birn couplings are the standard version manufactured from the electric melted quality cast iron, which warrants a homogeneous and faultless material.

LB type coupling is suitable for transmissions with special demands on dampend vibration. The transmission of torque is effected via rubber bushings especially shaped, to give the coupling a progressively increasing characteristic effectively dampening the torsional vibration at and in the critical speed of the machine unit.

The flexible rubber bushings of the coupling have an initial axial tension, which transmits the torque without slack and makes applications in both rotation directions possible. The coupling permits the mounting and dismounting of the motor or the machine, and the replacement of rubber bushings,

without axial displacement, when the bolts are removed from the coupling halves. The large deformation capacity of the rubber bushings, combined with self-lubricating properties, ensures that axial, radial, and angular misalignment are compensated for without considerable wear.

BICO range couplings are optimized with regard to power rating, outside dimensions, and shaft diameter. The flexible rubber traction gear rim effectively dampens vibrations and compensates axial, radial and angular misalignments. The range consists of two types, the BICO-TL and the BICO-S coupling. One flange of the BICO-TL can, without any problems, be installed together with a flange of a corresponding size of the BICO-S coupling.

BICO-TL type coupling with the Taper bush ensures quick and easy mounting and dismounting, and that the coupling is delivered ready for installation.

BICO-S type coupling with solid hub, can be bored to a larger shaft dimension than the TL type.

Mounting and dismounting as well as a replacement of the rubber element is only possible by axial displacement of the motor or the machine.



TECHNICAL DATA

Size of coupling LB	Power rating pr. revolution P/n	Torque TKN	Max speed		Moment of inertia ½ coupling ¹⁾ J	Weight 1/1 coupling ¹⁾ Kg
			for coupl. in GG n	for coupl. in GGG n		
Ref.	KW/rev.	Nm	r.p.m.	r.p.m.	Kgm ²	Kg
102	0,0046	44	5000	6000	0,00131	2,5
103	0,0102	98	4500	6000	0,00264	3,6
103½	0,0133	128	4500	6000	0,00245	3,9
104	0,0236	225	4000	6000	0,00500	5,7
105	0,0513	490	3600	5600	0,01349	10,0
106	0,0880	844	3000	5000	0,03335	17,3
107	0,1470	1403	2650	4500	0,07030	28,7
108	0,2210	2108	2250	4000	0,17365	46,8
109	0,3290	3140	2000	3600	0,28859	68,4
110	0,6160	5885	1800	3300	0,53246	98,2
111	0,7350	7024	1650	3000	0,90979	138,2
112	1,1030	10545	1500	2800	1,96171	216,4
114	1,6170	15450	1250	2500	3,19578	297,0
116	2,5050	23935	1120	2250	5,47170	411,0
118	3,6760	35120	1000	2000	10,18873	561,6

¹⁾ Valid for couplings with solid hubs

SERVICE FACTOR K FOR OPERATING MODE

Operating conditions	Driven machine		Driving machine		
	Moment of inertia relative to driving machine	Instantaneous shock	Uniform	Uneven oscillations	Uneven heavy oscillations
Uniform, no vibration	Insignificant	None	1,5	1,7	2,1
Uniform, no vibration	Minor	Insignificant	1,6	1,9	2,4
Uneven, low vibration	Identical	Minor	1,8	2,1	2,8
Uneven, vibration	High	Medium	2,0	2,4	3,2
Uneven, shocks with vibration	Very high	Heavy	2,6	2,8	3,6

RATIO Sd FOR OPERATING HOURS

h	Operating hours per day			
	above	2	8	16
up to	2	8	16	
Sd	0,9	1,0	1,12	1,25

The coupling must be designed, so that the occurring loads do not exceed the permissible values.

Calculation of the nominal torque:

$$TN = 9550 \times P/n \quad [Nm]$$

Calculation of the required coupling torque:

$$TKN \geq TN \times K \times Sd \times Sz \quad [Nm]$$

P = Output in KW n = r.p.m.

RATIO Sz FOR STARTING FREQUENCY

1/h	Number of starts per hour			
	above	1	20	40
up to	1	20	40	60
Sz	1,0	1,2	1,3	1,5

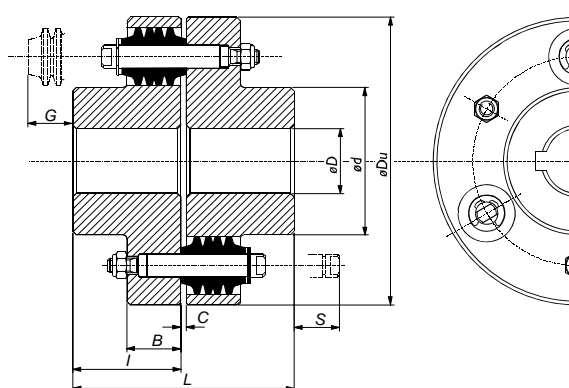

DIMENSIONS

Size of coupling LB	Max. bores D	Du	d	L	I	B	C	Dismounting dim.		Bolts per 1/1 coupl.
								Bushings G	Bolts S	
Ref.	mm	mm	mm	mm	mm	mm	mm	mm	mm	pc.
102	28	97	45	72,5	35	21	2,5	25	30	4
103	30	112	52	83,0	40	25	3,0	30	30	6
103½	38	112	63	92,5	45	21	2,5	30	30	8
104	42	130	68	103,0	50	25	3,0	25	30	8
105	50	160	82	123,0	60	30	3,0	25	25	8
106	65	190	110	153,0	75	30	3,0	10	25	10
107	75	225	125	183,5	90	38	3,5	15	30	10
108	90	270	150	204,0	100	45	4,0	20	35	8
109	110	300	180	244,0	120	45	4,0	5	35	10
110	115	340	185	284,0	140	55	4,0	0	35	10
111	140	380	220	324,0	160	55	4,0	0	35	10
112	160	440	250	364,5	180	68	4,5	0	40	8
114	180	500	280	404,5	200	68	4,5	0	40	10
116	200	560	305	445,0	220	83	5,0	0	40	10
118	220	640	330	505,0	250	83	5,0	0	40	12

TYPE OF RUBBER

Type	Characteristics	Temperature standard range	Wear resistance	Resistancy against oil
Ref.		°C		
NL	Natural rubber with canvas insertion standard quality for all common applications	-25 < t < +45	Very good	Inferior
N	Natural rubber, more flexible than type NL	-25 < t < +45	Very good	Inferior
F	Nitril rubber, especially used for couplings exposed to oil splashes	-20 < t < +60	Good	Very good

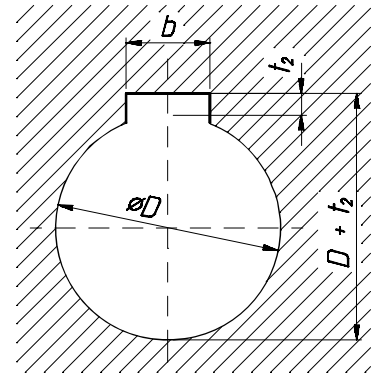
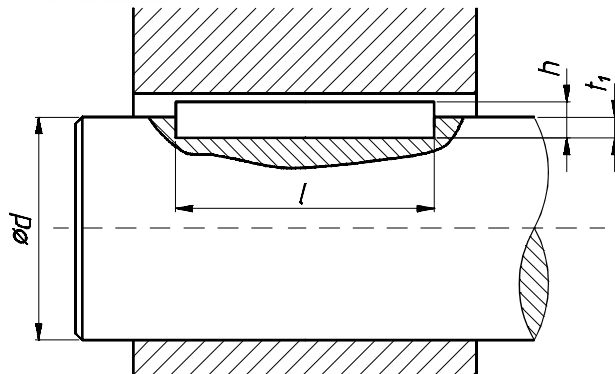

DIMENSIONS

Diameter		Keys cross-sect. b x h	Keyway depth		Tol. for t_1/t_2
above	up to		shaft t_1	hub t_2	
mm	mm	mm	mm	mm	mm
6	8	2 x 2	1,2	1,0	+ 0,1 0
8	10	3 x 3	1,8	1,4	
10	12	4 x 4	2,5	1,8	
12	17	5 x 5	3,0	2,3	
17	22	6 x 6	3,5	2,8	
22	30	8 x 7	4,0	3,3	+ 0,2 0
30	38	10 x 8	5,0	3,3	
38	44	12 x 8	5,0	3,3	
44	50	14 x 9	5,5	3,8	
50	58	16 x 10	6,0	4,3	
58	65	18 x 11	7,0	4,4	
65	75	20 x 12	7,5	4,9	
75	85	22 x 14	9,0	5,4	+ 0,3 0
85	95	25 x 14	9,0	5,4	
95	110	28 x 16	10,0	6,4	
110	130	32 x 18	11,0	7,4	
130	150	36 x 20	12,0	8,4	
150	170	40 x 22	13,0	9,4	+ 0,3 0
170	200	45 x 25	15,0	10,4	
200	230	50 x 28	17,0	11,4	

(ISO R 773: 1969)

ISO TOLERANCES

Nom. diameter		Bore		Shaft			
above	up to	H7	H8	k6	j6	g6	h7
mm	mm	μm	μm	μm	μm	μm	μm
6	10	+ 15 0	+ 22 0	+ 10 + 1	+ 7 - 2	- 5 - 14	0 - 15
10	18	+ 18 0	+ 27 0	+ 12 + 1	+ 8 - 3	- 6 - 17	0 - 18
18	30	+ 21 0	+ 33 0	+ 15 + 2	+ 9 - 4	- 7 - 20	0 - 21
30	50	+ 25 0	+ 39 0	+ 18 + 2	+ 11 - 5	- 9 - 25	0 - 25
50	80	+ 30 0	+ 46 0	+ 21 + 2	+ 12 - 7	- 10 - 29	0 - 30
80	120	+ 35 0	+ 54 0	+ 25 + 3	+ 13 - 9	- 12 - 34	0 - 35
120	180	+ 40 0	+ 63 0	+ 28 + 3	+ 14 - 11	- 14 - 39	0 - 40
180	250	+ 46 0	+ 72 0	+ 33 + 4	+ 16 - 13	- 15 - 44	0 - 46

(ISO 286-1: 1988)

FITS

Type of fit	Keyway width		Diameter		Characteristic of fit
	Shaft	Hub	Shaft	Hub	
Clearance fit	H8	D10	g6	H7	Movable
Clearance fit	N9	Js9	h7	H8	Easy mounting
Push fit Easy to pull out	P9	P9	j6	H7	For oscillation torques
Transition fit hard to pull out	P9	P9	k6	H7	Solid, only rarely dismounting

- 1) Generally keys should be used, the width "b" of which is machined to a tolerance "h9".
- 2) It is recommended, that the bearing length "l" of the key is machined to max. $l = 1,2 \times D$. A larger length does not cause an increase of torque transmission.
- 3) For reversing operation, and when heavy shock loads occur, it is recommended that the coupling is mounted with an interference fit.
- 4) The couplings are bored by using the diameter "Du" for set up.

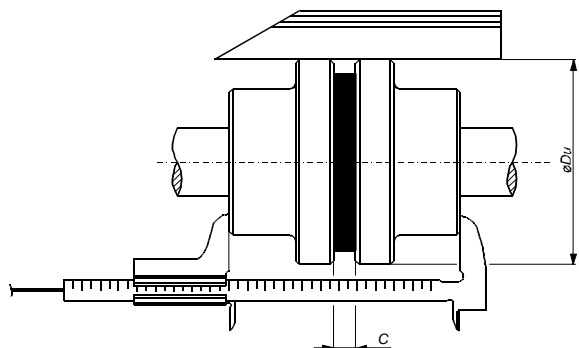

The coupling halves must be correctly mounted and aligned accurately before start-up. The couplings are bored by using diameter **Du** for setup. Ensure that the nuts on the bolts are loosened before installation, so that the rubber bushes are not tightened.

When mounting take care, that dimension **C** as mentioned in the tables of the particular coupling is maintained, in order to ensure the axial mobility of the coupling. Alignment may be carried out by means of a vernier caliper and a slide bar placed on the outside coupling diameter **Du**. Couplings are machined to a tolerance of IT 8. Alignment is carried out in two alternate 90° levels.

The couplings are capable of compensating either a radial or angular misalignment. The mentioned permissible misalignments are suggested values for revolutions less than 1000 rpm, for type LB 110 - 118 less than 500 rpm, and a service factor $\leq 2,5$. Higher numbers of revolutions and lower service factor require a more accurate alignment. A careful and accurate alignment will always increase the working life of the coupling.

Axial misalignment

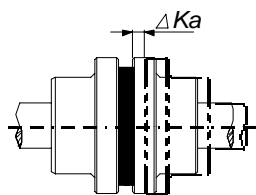

Radial misalignment

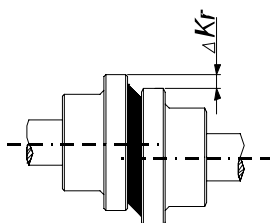

Angular misalignment

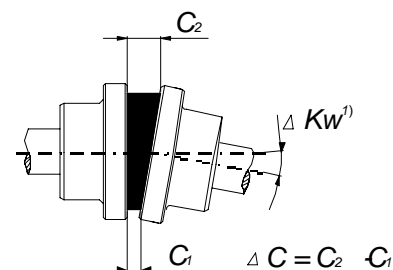

LB COUPLING

Size of coupling	Max. misalignment		
	ΔK_a	ΔK_r	ΔC
Ref.	mm	mm	mm
102	± 2,5	0,1	0,3
103	± 3,0	0,1	0,3
103½	± 2,5	0,1	0,3
104	± 3,0	0,1	0,3
105	± 3,0	0,1	0,4
106	± 3,0	0,1	0,4
107	± 3,5	0,2	0,5
108	± 4,0	0,2	0,6
109	± 4,0	0,2	0,6
110	± 4,0	0,2	0,8
111	± 4,0	0,2	0,8
112	± 4,5	0,3	1,0
114	± 4,5	0,3	1,0
116	± 5,0	0,3	1,5
118	± 5,0	0,3	1,5

BICO COUPLING

Size of coupling	Max. misalignment		
	ΔK_a	ΔK_r	ΔC
Ref.	mm	mm	mm
70	+ 0,2	0,3	0,5
90	+ 0,5	0,3	0,5
110	+ 0,6	0,3	1,0
130	+ 0,8	0,4	1,0
150	+ 0,9	0,4	1,5
180	+ 1,1	0,4	1,5
230	+ 1,3	0,5	2,0
280	+ 1,7	0,5	2,5

1) The permissible angular misalignment ΔK_w is in the tables mentioned as the measurable dimension ΔC .



Taper Bush

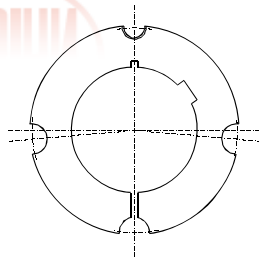

2 x
Type A

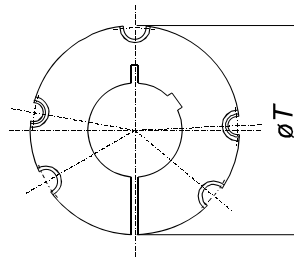

3 x
Type B

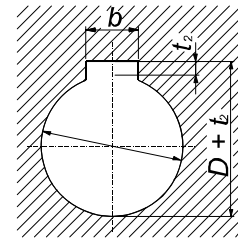

D mm	b mm	t ₂	*	Size							
				1008	1108	1210	1610	2012	2517	3020	3525
9	3	1,4	-	•	•						
10	3	1,4	-	•	•						
11	4	1,8	-	•	•	•					
12	4	1,8	-	•	•	•					
14	5	2,3	-	•	•	•	•	•			
16	5	2,3	-	•	•	•	•	•	•		
18	6	2,8	-	•	•	•	•	•	•		
19	6	2,8	-	•	•	•	•	•	•		
20	6	2,8	-	•	•	•	•	•	•		
22	6	3,3	-	•	•	•	•	•	•		
24	8	3,3	1,3	•*	•	•	•	•	•		
25	8	3,3	1,3	•*	•	•	•	•	•	•	
28	8	3,3	1,3		•*	•	•	•	•	•	
30	8	3,3	-			•	•	•	•	•	
32	10	3,3	-			•	•	•	•	•	
35	10	3,3	-				•	•	•	•	•
38	10	3,3	-				•	•	•	•	•
40	12	3,3	1,3				•*	•	•	•	•
42	12	3,3	1,3				•*	•	•	•	•
45	14	3,8	-					•	•	•	•
48	14	3,8	-					•	•	•	•
50	14	3,8	-					•	•	•	•
55	16	4,3	-						•	•	•
60	18	4,4	-						•	•	•
65	18	4,4	-							•	•
70	20	4,9	-							•	•
75	20	4,9	-							•	•
80	22	5,4	-								•
85	22	5,4	-								•
90	25	5,4	-								•
100	28	6,4	-								•
TYPE				A	A	A	A	A	A	A	B
T			mm	35,0	38,0	47,5	57,0	70,0	85,5	108,0	127,0
Appr. weight			kg	0,1	0,1	0,2	0,3	0,7	1,5	2,7	3,8
Screws			B.S.W.	1/4" x 1/2"	1/4" x 1/2"	3/8" x 5/8"	3/8" x 5/8"	7/16" x 7/8"	1/2" x 1"	5/8" x 1 1/4"	1/2" x 1 1/2"
Tightening torque			Nm	5,6	5,6	20	20	31	48	90	113

*Bush with reduced height for keyway



IEC Standard motors and matching BIRN couplings

MOTOR		COUPLING																																														
Type	Shaft dia.	Motor power	3000 r.p.m.			1500 r.p.m.			1000 r.p.m.			750 r.p.m.																																				
			LB	BICO		Motor power	LB	BICO		Motor power	LB	BICO		Motor power	LB	BICO																																
Ref.	mm	KW	Ref.	Ref.	Ref.	KW	Ref.	Ref.	Ref.	KW	Ref.	Ref.	Ref.	KW	Ref.	Ref.	Ref.																															
63B	14	0,25	102	70TL	70S	0,18	102	70TL	70S	0,12	102	70TL	70S	0,055	102	70TL	70S																															
63D																		0,18																														
71																																																
71A																		0,37				0,25				0,18				0,09																		
71B																		0,55				0,37				0,25				0,12																		
80A	19	0,75																			0,55				0,37				0,13																			
80B		1,1																			0,75				0,55				0,18																			
90S		1,5																			1,1				0,75				0,37																			
90L	24	2,2																			1,5				1,1				0,55																			
100L	28	3																103½	90TL	90S	2,2	103½	130TL	110S	1,5	104	130TL	110S	0,75	104	130TL	110S																
100LA																																																
100LB							3								1,1																																	
112M			4				4	103		90S	2,2				1,5																																	
132S							5,5				3				2,2																		90S															
132SA	38	5,5																																														
132SB		7,5																																														
132M						7,5								3																																		
132MA											4																						110S															
132MB											5,5																																					
160MA	42	11	105	150TL	110S	11	104	150TL	130S	7,5	104	150TL	130S	4	104	150TL	130S																															
160M		15																																														
160L		18,5																				15				11				7,5																		
180M	48	22																			18,5												130S															
180L																									15				11																			
200LA	55	30																106	180TL	130S	30	106	180TL	150S	22	106	180TL	150S	15	106	180TL	150S																
200L		37																																														
225S	55/60																																			37								18,5				180S
225M		45																																		45				30				22				
250M	60/65	55																																		55				37				30				
280S	65/75	75				75				45				37																			230TL															
280M		90				90				55				45																			230S															
315S			110				110				75				55																																	
315MA	65/80	132	107	230TL	180S	132	108	280TL	230S	90	108	280TL	230S	75	108	280TL	230S																															
315MB		160																																														
355S	80/100	200																			200				132				110																			
355MA		250																			250				160				132																			
355MB		280																			315	110			200				160																			
355MC																										250																						

The couplings are selected for standard operation conditions with a service factor of min. 2.
For vibration or shock-load torque we recommend a check calculation.



MATERIAL

All cast iron used for the couplings is electrically melted quality cast iron. This gives the iron an increased degree of purity and quality. Electrically melted iron contains only a minimum of contaminating matters as e. g. phosphor and sulphur.

Therefore it has a very close-grained structure without microporosities. Because of the high degree of purity gas holes in the cast iron are avoided.

SPECIFICATIONS

Properties		Quality grade			
		Standard type - grey iron			Special type SG iron GGG40
		GG25	GG30	GG35	
Tensile strength	N/mm ²	250	300	350	400
Elongation	%				15
DIN 1691/1693	Ref.	GG25	GG30	GG35	GGG40

BALANCING

LB and BICO-TL couplings are supplied with a max. static unbalance, balanced in one plane, according to quality grade G16¹⁾. Upon request the couplings can be supplied balanced in two planes, dynamic unbalance, according to quality grade G16 or G6,3.

Balancing in two planes is only carried out on couplings with finished bores.

BICO-S couplings supplied ex stock are not balanced. Balancing is carried out only upon request.

¹⁾ Designation according to ISO 1940

PACKING

LB couplings are protected completely with red anticorrosion paint. The coupling halves are packed separately in solid cardboard boxes or wooden cases.

BICO couplings are zincphosphated and oiled. They are not separately packed. Taper-bushings are packed in cardboard boxes together with screws and mounting instructions.

INQUIRES

When inquiring or ordering please state:

- 1) If coupling is to be supplied without or with bore. If the latter case please state shaft diameter, tolerance and size of keyway.
- 2) Required rubber quality.
- 3) Type of driving in respect of driven machine.
- 4) Max. transmitted power, starting torque, shock-load value.
- 5) Revolutions per minute.

CONVERSION FACTOR

Power: $P = 1 \text{ [KW]} = 1,36 \text{ [HP]}$

Torque: $T = 1 \text{ [Nm]} = 0,102 \text{ [Kpm]}$

Moment of inertia: $J = \frac{1}{2} m \times r^2 = m \times D^2 / 8 = (G \times D^2) / 8 \text{ [Kgm}^2\text{]}$

Peripheral speed: $V = n \times D \times \pi \times 1/60 \text{ [m/s]}$