

RCK 40 - Nesamostředící/Not self-centring
Kompaktní pouzdra/Compact Units

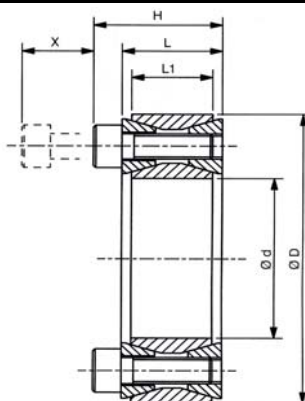

Doporučená tolerance: Hřídel-h9, Náboj-H9

Recommended tolerances: Shaft-h9, Hub-H9

Drsnost povrchu: Rt max. 16µm

Clamping surfaces: R_{tmax}. 16µm

Materiál: ST = ocel C43 / ST = steel C43

Upínací pouzdra RCK40 - nesamostředící / Clamping Elements RCK40 - Not self-centring

Označení / Obj.č. Part.No.	Rozměry / Dimensions					Moment/ Torque Mt [Nm]	Tlak/Pressure			Up.šrouby/Clamp.Screws			Uvolň./Extr.		Hmot/ Weight [kg]
	d [mm]	D [mm]	L1 [mm]	L3 [mm]	L [mm]		Hř./Shaft [N/mm2]	Náb./Hub [N/mm2]	Počet/ No.	Typ/ Type	Moment/ Torq.Nm	Typ/ Type	Počet/ No.		
RCK40-19x47	19	47	17	20	28	255	220	90	8	M6x18	14	M8	2	0.25	
RCK40-20x47	20	47	17	20	28	270	210	90	8	M6x18	14	M8	2	0.24	
RCK40-22x47	22	47	17	20	28	300	195	90	8	M6x18	14	M8	2	0.23	
RCK40-24x50	24	50	17	20	28	360	195	95	9	M6x18	14	M8	3	0.26	
RCK40-25x50	25	50	17	20	28	380	190	95	9	M6x18	14	M8	3	0.25	
RCK40-28x55	28	55	17	20	28	500	187	96	10	M6x18	14	M8	4	0.30	
RCK40-30x55	30	55	17	20	28	530	176	96	10	M6x18	14	M8	4	0.29	
RCK40-32x60	32	60	17	20	28	630	192	105	12	M6x18	14	M8	4	0.34	
RCK40-35x60	35	60	17	20	28	700	180	105	12	M6x18	14	M8	4	0.32	
RCK40-38x65	38	65	17	20	28	860	183	107	14	M6x18	14	M8	4	0.36	
RCK40-40x65	40	65	17	20	28	910	180	110	14	M6x18	14	M8	4	0.34	
RCK40-42x75	42	75	20	24	34	1500	226	125	12	M8X22	35	M10	4	0.60	
RCK40-45x75	45	75	20	24	34	1610	210	125	12	M8X22	35	M10	4	0.57	
RCK40-48x80	48	80	20	24	34	1700	196	115	12	M8X22	35	M10	4	0.63	
RCK40-50x80	50	80	20	24	34	1770	190	115	12	M8X22	35	M10	4	0.60	
RCK40-55x85	55	85	20	24	34	2270	200	130	14	M8X22	35	M10	4	0.63	
RCK40-60x90	60	90	20	24	34	2470	180	120	14	M8X22	35	M10	4	0.69	
RCK40-65x95	65	95	20	24	34	3040	190	130	16	M8X22	35	M12	4	0.73	
RCK40-70x110	70	110	24	28	40	4600	210	130	14	M10x25	70	M12	4	1,26	
RCK40-75x115	75	115	24	28	40	4900	195	125	14	M10x25	70	M12	4	1,33	
RCK40-80x120	80	120	24	28	40	5200	180	120	14	M10x25	70	M12	4	1,40	
RCK40-85x125	85	125	24	28	40	6300	195	130	16	M10x25	70	M12	4	1,49	
RCK40-90x130	90	130	24	28	40	6600	180	125	16	M10x25	70	M12	4	1,53	
RCK40-95x135	95	135	24	28	40	7900	195	135	18	M10x25	70	M12	4	1,62	
RCK40-100x145	100	145	26	33	47	9600	195	135	14	M12x30	125	M14	4	2,01	
RCK40-110x155	110	155	26	33	47	10500	180	125	14	M12x30	125	M14	4	2,15	
RCK40-120x165	120	165	26	33	47	13100	185	135	16	M12x30	125	M14	4	2,35	
RCK40-130x180	130	180	34	38	52	17600	165	115	20	M12x35	125	M14	4	3,51	
RCK40-140x190	140	190	34	38	52	20900	165	125	22	M12x35	125	M14	4	3,85	
RCK40-150x200	150	200	34	38	52	24200	170	125	24	M12x35	125	M14	4	4,07	
RCK40-160x210	160	210	34	38	52	28000	170	130	26	M12x35	125	M14	4	4,30	
RCK40-170x225	170	225	38	44	60	32800	160	120	22	M14x40	190	M18	4	5,78	
RCK40-180x235	180	235	38	44	60	37800	165	125	24	M14x40	190	M16	4	6,05	
RCK40-190x250	190	250	46	52	68	46500	150	115	28	M14x45	190	M16	4	8,25	
RCK40-200x260	200	260	46	52	68	52500	150	115	30	M14x45	190	M16	5	8,65	
RCK40-220x285	220	285	50	56	74	68000	150	115	26	M16x50	295	M18	4	11,25	